



PARTS CATALOGUE

YZ250FS '04 (5XC4) SOUTH AFRICA

YZ250FS



A4

FOREWORD

This Parts Catalogue is related to the parts for the model(s) on the cover page. When you are ordering replacement parts, please refer to this Parts Catalogue and quote both part numbers and part names correctly.

1. Modifications or additions which have been made after the issue of the Parts Catalogue will be announced in the Parts News.

It is advisable that you make the necessary corrections to the Parts Catalogue according to the Parts News.

2. Abbreviations

The following abbreviations are used in this Parts Catalogue.

“UR” Use specified parts number.

“UN” Use as many as needed.

“AP” Alternate Parts

“LM” Locally Made (Parts need to be ordered locally)

“F#” Frame No. (Applicable machine No.)

“O/S” Over Size

3. The number of components for assembly

- Parts, which are to be supplied in an assembly, are listed with a dot (.) in front of the part name as shown below.
- The numeral appearing to the right of each component part indicates the quantity of parts for each assembly unit.

PART NO.	DESCRIPTION	Q'TY	REMARKS
2F5-83310-60	FRONT FLASHER LIGHT ASSY	2	
115-83311-60	.BULB (6V-18W)	1	

4. Applicable colours of graphics are represented in the “REMARKS” as shown below.

PART NO.	DESCRIPTION	Q'TY	REMARKS
2N4-24110-00-X5	FUEL TANK COMP.	2	MXR
3J1-24240-10	.GRAPHIC, FUEL TANK	1	FOR MXR

5. Note that the illustrations for reference in finding parts numbers are not to be used for assembling. When assembling, please use the applicable service manual.

6. The asterisk (*) before a reference number indicates modified items after the first edition.

FOREWORD

7. Applicable Serial No.

Engine Serial No.

Frame Serial No.

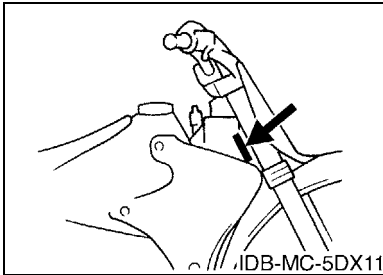
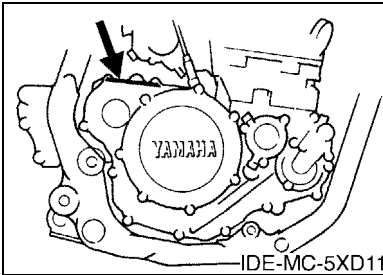

8. Applicable Colour Code (The (*) mark shows Model colour.)

Abbreviation	Colour Name	Colour Code
DPBSE(*)	DEEP PURPLISH BLUE SOLID E	0583

MODEL LABEL

(1) A label called "Model Label" is affixed in the location as indicated in (3) below. When using this parts catalogue, please be sure to cross-reference the "model code – production code No." in the catalogue with the "model code – production code No." indicated on the Model Label affixed onto the product concerned.

(2) "Model Label" Indication

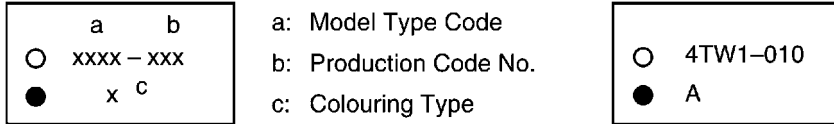

(3) Model Label Affixing Location

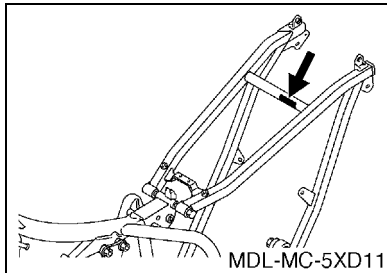

(4) Colouring Information

Model Code	Colouring Type Code	Colour Code	Colour Name	Abbreviation
5XC4	A	0583	DEEP PURPLISH BLUE SOLID E	DPBSE

(5) Model Code – Production Code Number of Model Listed in This Parts Catalogue

Model Code	Production Code No.	Country (destination)	Model Code	Production Code No.	Country (destination)
5XC4	010	AUSTRALIA			
		NEW ZEALAND			
		SOUTH AFRICA			
	020	CANADA			

CONTENTS

ENGINE

CYLINDER	B2
CRANKSHAFT & PISTON	B4
VALVE	B5
CAMSHAFT & CHAIN	B7
WATER PUMP	B8
RADIATOR & HOSE	B9
OIL PUMP	B10
OIL CLEANER	B11
INTAKE	B12
CARBURETOR	B13
EXHAUST	C3
CRANKCASE	C4
CRANKCASE COVER 1	C5
STARTER	C7
CLUTCH	C8
TRANSMISSION	C10
SHIFT CAM & FORK	C12
SHIFT SHAFT	C13

CHASSIS

FRAME	C14
FENDER	D2
SIDE COVER	D3
REAR ARM	D4
REAR SUSPENSION	D6
STEERING	D8
FRONT FORK	D9
FUEL TANK	D11
SEAT	D13
FRONT WHEEL	D14
FRONT BRAKE CALIPER	D15
REAR WHEEL	E2
REAR BRAKE CALIPER	E4
STEERING HANDLE & CABLE	E5
FRONT MASTER CYLINDER	E6
STAND & FOOTREST	E7
REAR MASTER CYLINDER	E8
GENERATOR	E9
HANDLE SWITCH & LEVER	E10
ELECTRICAL 1	E11
ALTERNATE FOR CHASSIS	E12

ALTERNATE DECOMPRESSION KIT	E14
-----------------------------------	-----

INDEX

NUMERICAL INDEX	M1
-----------------------	----

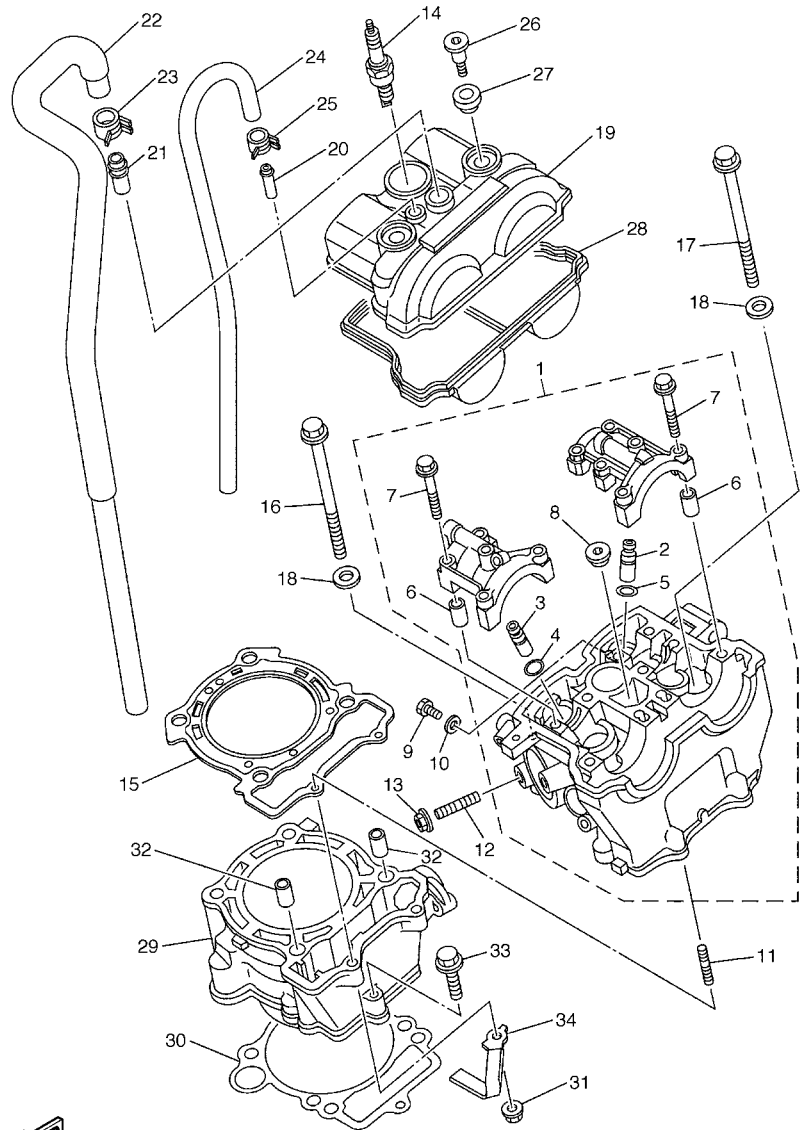

5XC1100-C010

FIG. 1 CYLINDER

REF. NO.	PART NO.	DESCRIPTION	5XC1	5XC2	5XC3	5XC4	REMARKS
1	5NL-11102-20	CYLINDER HEAD ASSY	1	1	1	1	
2	5NL-11133-10	.GUIDE, VALVE 1	3	3	3	3	
3	5NL-11134-10	.GUIDE, VALVE 2	2	2	2	2	
4	93440-10153	.CIRCLIP	2	2	2	2	
5	93440-07149	.CIRCLIP	3	3	3	3	
6	91808-16023	.PIN, DOWEL	4	4	4	4	
7	90105-06027	.BOLT, FLANGE	10	10	10	10	
8	90340-12112	.PLUG, STRAIGHT SCREW	1	1	1	1	
9	95027-06010	BOLT, FLANGE	1	1	1	1	
10	90430-06014	GASKET	1	1	1	1	
11	90116-06541	BOLT, STUD	2	2	2	2	
12	95617-08620	BOLT, STUD	1	1	1	1	
13	95707-08500	NUT, FLANGE	1	1	1	1	
14	NGK-CR8E-PK10	PLUG, SPARK (NGK R CR8E)	1	1		1	STD
	NGK-CR9E-PK10	PLUG, SPARK (NGK R CR9E)	1	1		1	AP
15	5NL-11181-00	GASKET, CYLINDER HEAD 1	1	1	1	1	
16	90105-09555	BOLT, FLANGE	2	2	2	2	
17	90105-09002	BOLT, FLANGE	2	2	2	2	
18	90201-096J9	WASHER, PLATE	4	4	4	4	
19	5NL-11191-00	COVER, CYLINDER HEAD 1	1	1	1	1	
20	5BE-11167-00	PIPE, BREATHER 2	1	1	1	1	
21	371-11167-01	PIPE, BREATHER 2	1	1	1	1	
22	5TA-11166-00	PIPE, BREATHER 1	1	1	1	1	
23	90467-14015	CLIP	1	1	1	1	
24	90445-112K0	HOSE (L285)	1	1	1	1	

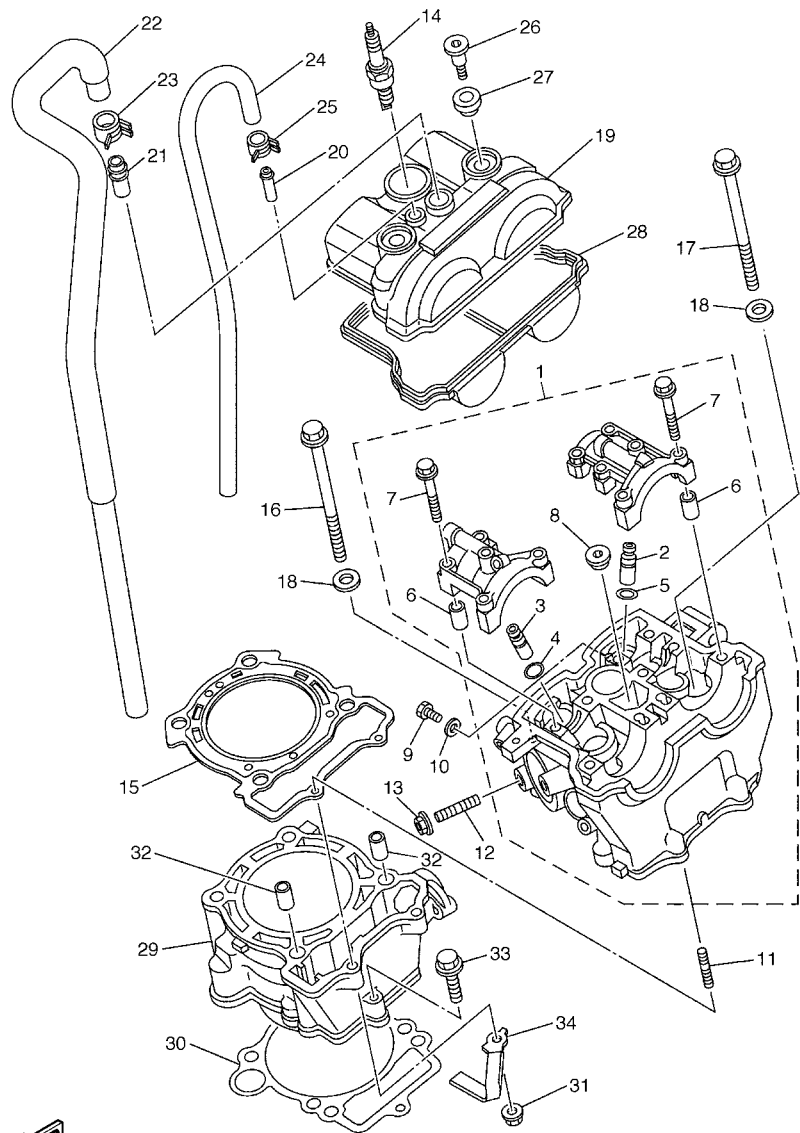

5XC1100-C010

FIG. 1 CYLINDER

REF. NO.	PART NO.	DESCRIPTION	5XC1	5XC2	5XC3	5XC4	REMARKS
25	90467-11106	CLIP	2	2	2	2	
26	90109-066F0	BOLT	2	2	2	2	
27	4KG-1111G-00	RUBBER, MOUNT 1	2	2	2	2	
28	5NL-11193-00	GASKET, HEAD COVER 1	1	1	1	1	
29	5XC-11311-00	CYLINDER 1	1	1	1	1	
30	5NL-11351-00	GASKET, CYLINDER	1	1	1	1	
31	95704-06500	NUT, FLANGE	2	2	2	2	
32	93612-16254	PIN, DOWEL	2	2	2	2	
33	95027-06035	BOLT, FLANGE	1	1	1	1	
34	5UM-11387-00	CLAMP, HOSE 1	1	1	1	1	

FIG. 2 CRANKSHAFT & PISTON

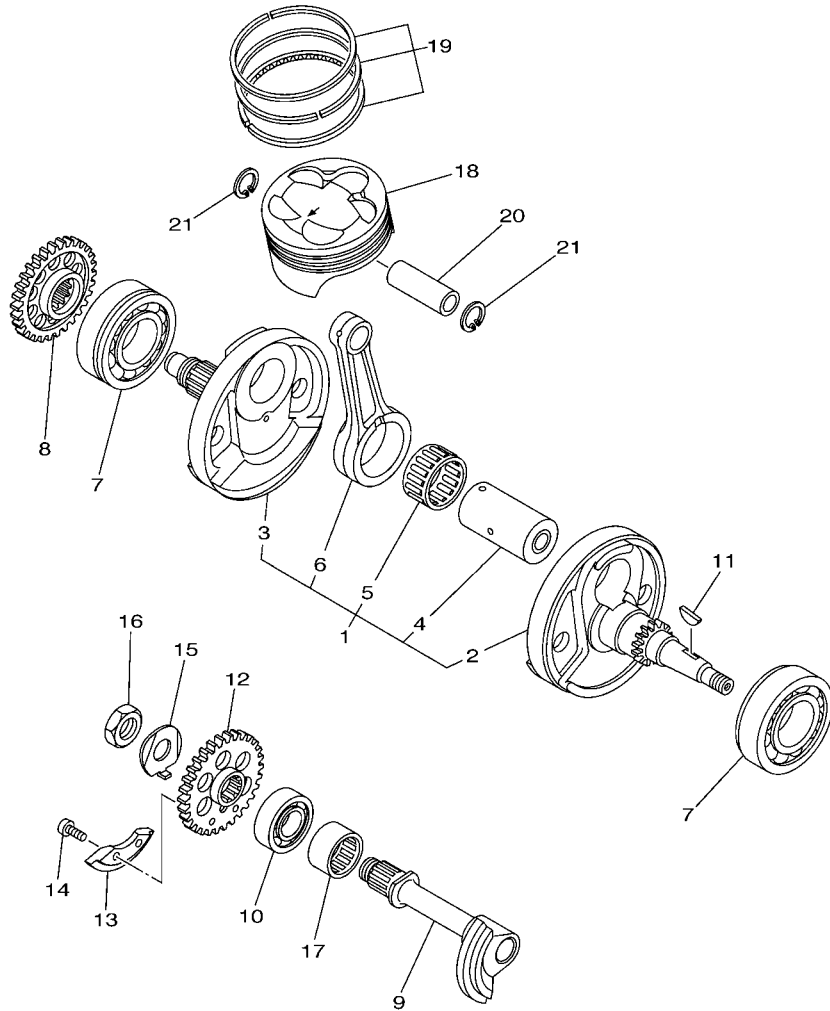

FWD
5NL1100-1020

REF. NO.	PART NO.	DESCRIPTION	5XC1	5XC2	5XC3	5XC4	REMARKS
1	5XC-11400-00	CRANKSHAFT ASSY	1	1	1	1	
2	5UL-11412-10	.CRANK 1	1	1	1	1	
3	5UL-11422-00	.CRANK 2	1	1	1	1	
4	5XC-11681-00	.PIN, CRANK 1	1	1	1	1	
5	93310-63238	.BEARING	1	1	1	1	
6	5UL-11651-00	.ROD, CONNECTING	1	1	1	1	
7	93306-20648	BEARING	2	2	2	2	
8	5NL-11536-00	GEAR, DRIVE	1	1	1	1	
9	5NL-11455-00	SHAFT 1	1	1	1	1	
10	93306-20335	BEARING	1	1	1	1	
11	90280-03001	KEY, WOODRUFF	1	1	1	1	
12	5NL-11531-00	GEAR, BALANCE WEIGHT	1	1	1	1	
13	5NL-11454-00	WEIGHT 1	1	1	1	1	
14	90149-06250	SCREW	2	2	2	2	
15	90215-14204	WASHER, LOCK	1	1	1	1	
16	90170-14171	NUT	1	1	1	1	
17	93311-32261	BEARING	1	1	1	1	
18	5NL-11631-10	PISTON (STD)	1	1	1	1	
19	5NL-11603-00	PISTON RING SET (STD)	1	1	1	1	
20	5NL-11633-00	PIN, PISTON	1	1	1	1	
21	93420-16086	CIRCLIP	2	2	2	2	

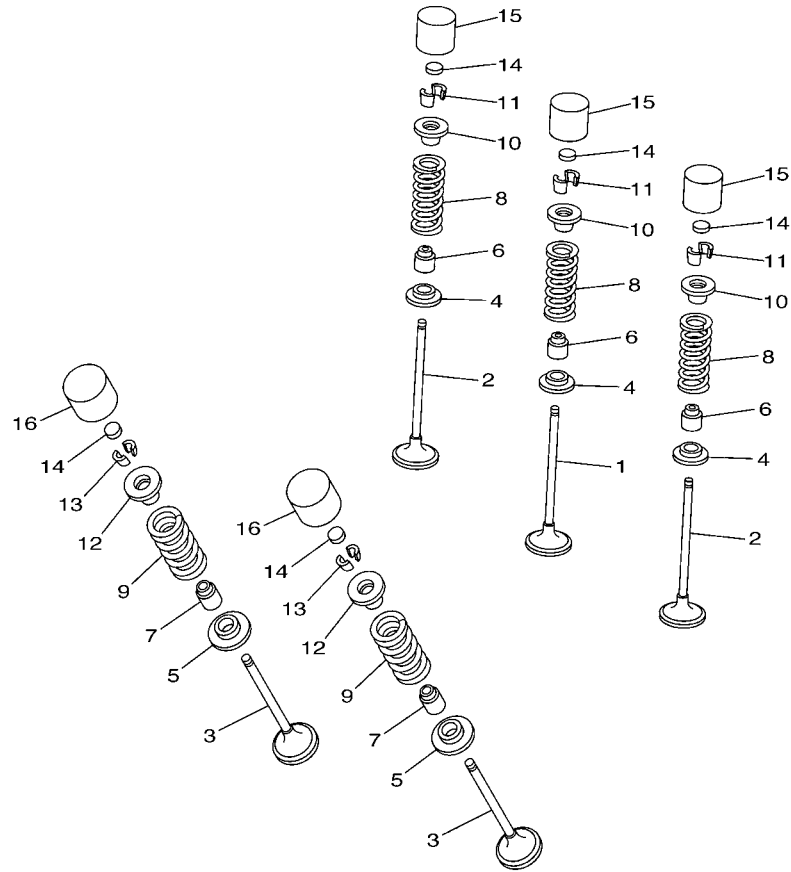

FIG. 3 VALVE

REF. NO.	PART NO.	DESCRIPTION	5XC1	5XC2	5XC3	5XC4	REMARKS
1	5NL-12111-10	VALVE, INTAKE	1	1	1	1	
2	5NL-12112-10	VALVE, INTAKE 2	2	2	2	2	
3	5NL-12121-10	VALVE, EXHAUST	2	2	2	2	
4	5NL-12116-00	SEAT, VALVE SPRING	3	3	3	3	
5	3GM-12126-00	SEAT, VALVE SPRING 2	2	2	2	2	
6	4TV-12119-00	SEAL, VALVE STEM	3	3	3	3	
7	4SV-12119-00	SEAL, VALVE STEM	2	2	2	2	
8	5NL-12113-00	SPRING, VALVE INNER	3	3	3	3	
9	5NL-12114-00	SPRING, VALVE OUTER	2	2	2	2	
10	1HX-12117-00	RETAINER, VALVE SPRING	3	3	3	3	
11	1HX-12118-00	COTTER, VALVE	6	6	6	6	
12	1WG-12117-00	RETAINER, VALVE SPRING	2	2	2	2	
13	1WG-12118-00	COTTER, VALVE	4	4	4	4	
14	1HX-12168-00	PAD, ADJUSTING 2 (1.20)	5	5	5	5	UR
	1HX-12168-20	PAD, ADJUSTING 2 (1.25)	5	5	5	5	UR
	1HX-12168-40	PAD, ADJUSTING 2 (1.30)	5	5	5	5	UR
	1HX-12168-60	PAD, ADJUSTING 2 (1.35)	5	5	5	5	UR
	1HX-12168-80	PAD, ADJUSTING 2 (1.40)	5	5	5	5	UR
	1HX-12168-A0	PAD, ADJUSTING 2 (1.45)	5	5	5	5	UR
	1HX-12168-F0	PAD, ADJUSTING 2 (1.50)	5	5	5	5	UR
	1HX-12168-H1	PAD, ADJUSTING 2 (1.55)	5	5	5	5	UR
	1HX-12168-K1	PAD, ADJUSTING 2 (1.60)	5	5	5	5	UR
	1HX-12168-M1	PAD, ADJUSTING 2 (1.65)	5	5	5	5	UR
	1HX-12168-R1	PAD, ADJUSTING 2 (1.70)	5	5	5	5	UR
	1HX-12168-U1	PAD, ADJUSTING 2 (1.75)	5	5	5	5	UR
	1HX-12168-W1	PAD, ADJUSTING 2 (1.80)	5	5	5	5	UR
	1HX-12168-Y1	PAD, ADJUSTING 2 (1.85)	5	5	5	5	UR



5NL1100-1030

B5

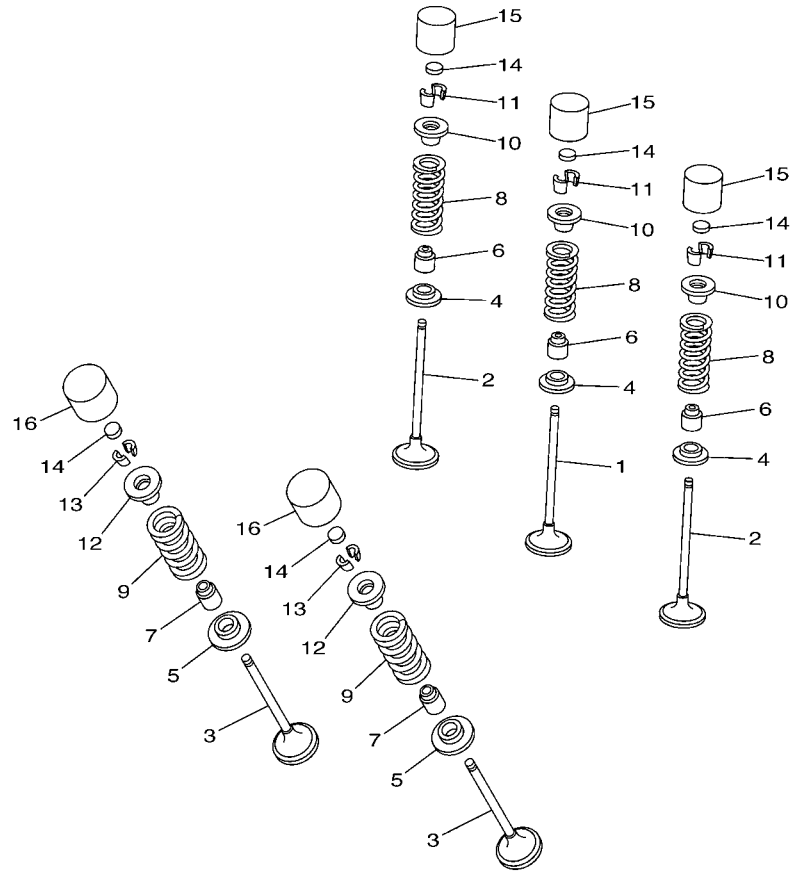
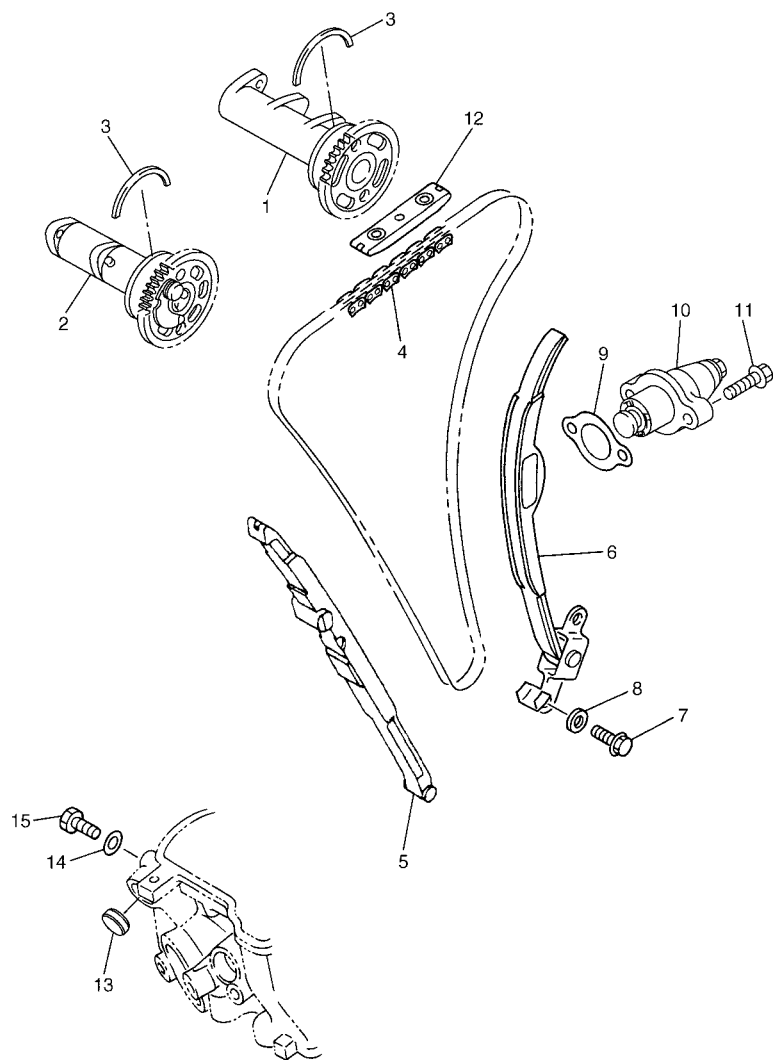

FIG. 3 VALVE

REF. NO.	PART NO.	DESCRIPTION	SXC1	SXC2	SXC3	SXC4	REMARKS
14	1HX-12169-11	PAD, ADJUSTING 2 (1.90)	5	5	5	5	UR
	1HX-12169-31	PAD, ADJUSTING 2 (1.95)	5	5	5	5	UR
	1HX-12169-50	PAD, ADJUSTING 2 (2.00)	5	5	5	5	UR
	1HX-12169-70	PAD, ADJUSTING 2 (2.05)	5	5	5	5	UR
	1HX-12169-90	PAD, ADJUSTING 2 (2.10)	5	5	5	5	UR
	1HX-12169-E0	PAD, ADJUSTING 2 (2.15)	5	5	5	5	UR
	1HX-12169-G0	PAD, ADJUSTING 2 (2.20)	5	5	5	5	UR
	1HX-12169-J0	PAD, ADJUSTING 2 (2.25)	5	5	5	5	UR
	1HX-12169-L0	PAD, ADJUSTING 2 (2.30)	5	5	5	5	UR
	1HX-12169-N0	PAD, ADJUSTING 2 (2.35)	5	5	5	5	UR
	1HX-12169-T0	PAD, ADJUSTING 2 (2.40)	5	5	5	5	UR
15	3LN-12153-10	LIFTER, VALVE	3	3	3	3	UR YELLOW
	3LN-12153-09	LIFTER, VALVE (O/S)	3	3	3	3	UR GREEN
16	3FV-12153-10	LIFTER, VALVE	2	2	2	2	UR YELLOW
	3FV-12153-09	LIFTER, VALVE (O/S)	2	2	2	2	UR GREEN



5NL1100-1030

FIG. 4 CAMSHAFT & CHAIN

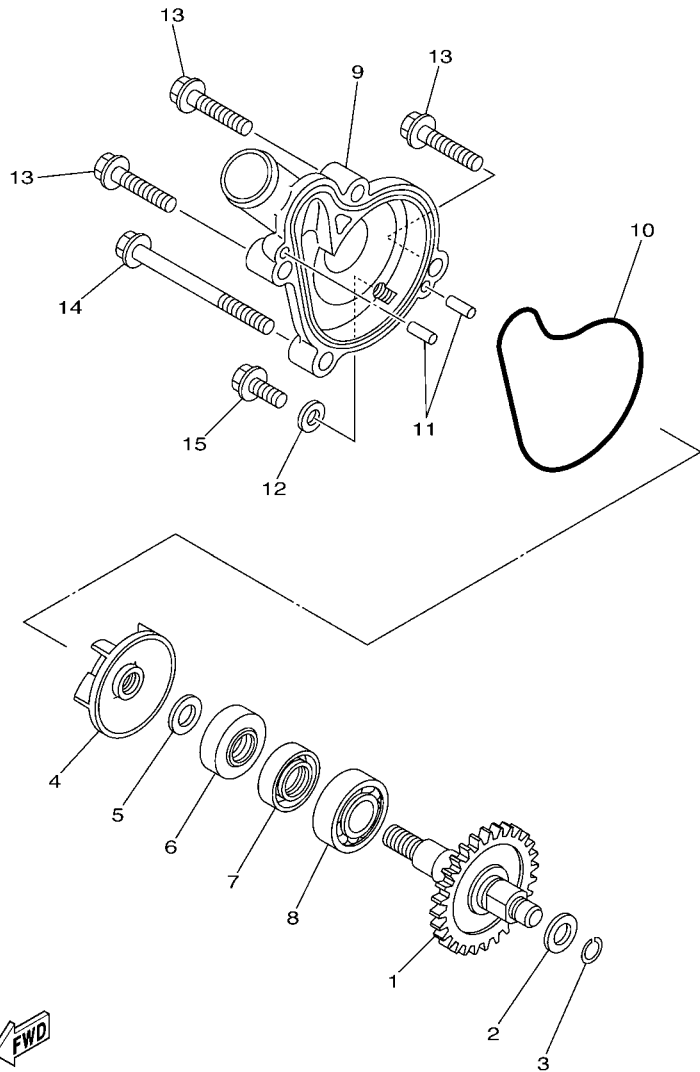

5UL1100-B040

REF. NO.	PART NO.	DESCRIPTION	5XC1	5XC2	5XC3	5XC4	REMARKS
1	5UL-12170-00	CAMSHAFT ASSY 1	1	1	1	1	
2	5UL-12180-00	CAMSHAFT ASSY 2	1	1	1	1	
3	93440-41178	CIRCLIP	2	2	2	2	
4	94591-53114	CHAIN	1	1	1	1	
5	5NL-12251-00	DAMPER, CHAIN 1	1	1	1	1	
6	5NL-12252-00	DAMPER, CHAIN 2	1	1	1	1	
7	97027-06016	BOLT	2	2	2	2	
8	92907-06600	WASHER, PLATE	2	2	2	2	
9	4FM-12213-00	GASKET, TENSIONER CASE	1	1	1	1	
10	5TA-12210-00	TENSIONER ASSY, CAM CHAIN	1	1	1	1	
11	95027-06025	BOLT, FLANGE	2	2	2	2	
12	5BE-12241-00	GUIDE, STOPPER 2	1	1	1	1	
13	90338-18064	PLUG	1	1	1	1	
14	90430-06014	GASKET	1	1	1	1	
15	90109-06418	BOLT	1	1	1	1	



FWD
5NL1100-1050

FIG. 5 WATER PUMP

REF. NO.	PART NO.	DESCRIPTION	5XC1	5XC2	5XC3	5XC4	REMARKS
1	5XC-12459-00	GEAR, IMPELLER SHAFT	1	1	1	1	
2	90201-08512	WASHER, PLATE	1	1	1	1	
3	93440-07182	CIRCLIP	1	1	1	1	
4	5DH-12451-00	IMPELLER, WATER PUMP	1	1	1	1	
5	90201-08512	WASHER, PLATE	1	1	1	1	
6	93109-11073	OIL SEAL	1	1	1	1	
7	93102-12106	OIL SEAL (SD 12-22-5 HS)	1	1	1	1	
8	93306-00105	BEARING (B6001)	1	1	1	1	
9	5NL-12422-10	COVER, HOUSING	1	1	1	1	
10	5NL-12439-00	O-RING	1	1	1	1	
11	93604-10011	PIN, DOWEL	2	2	2	2	
12	90430-06014	GASKET	1	1	1	1	
13	95027-06025	BOLT, FLANGE	3	3	3	3	
14	95027-06065	BOLT, FLANGE	1	1	1	1	
15	95027-06012	BOLT, FLANGE	1	1	1	1	

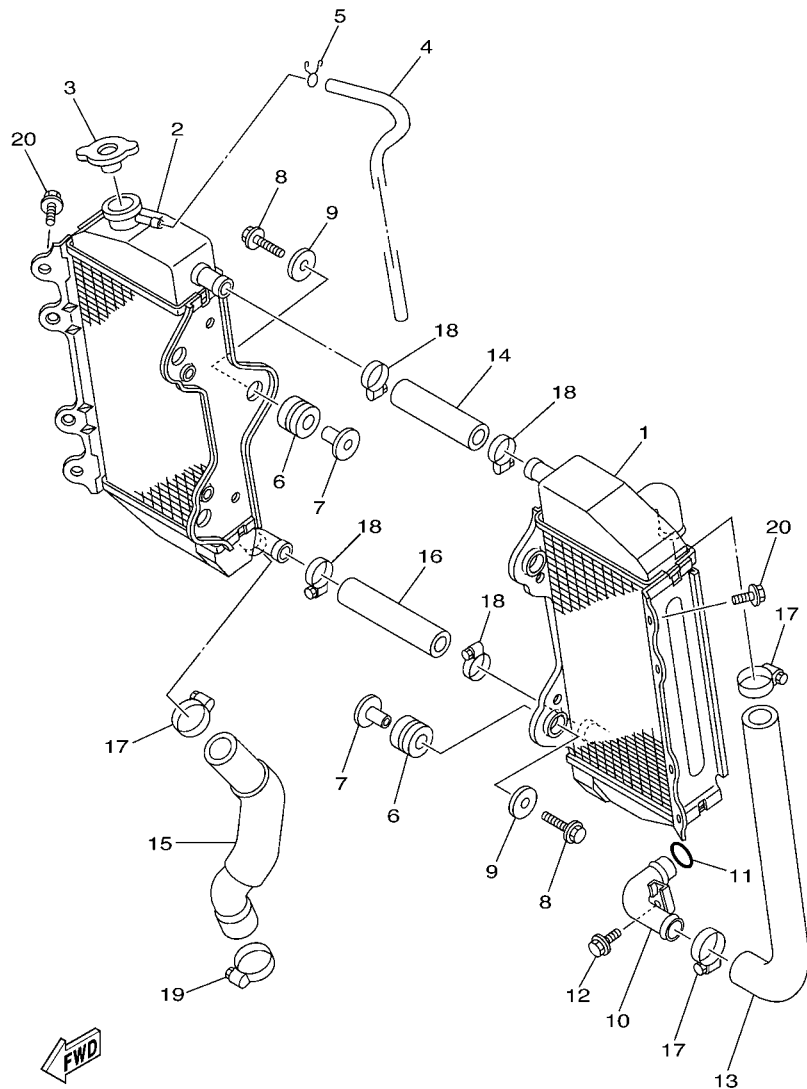

5NL1100-1060

FIG. 6 RADIATOR & HOSE

REF. NO.	PART NO.	DESCRIPTION	5XC1	5XC2	5XC3	5XC4	REMARKS
1	5NL-1240A-10	RADIATOR ASSY	1	1	1	1	
2	5NL-12461-10	RADIATOR ASSY	1	1	1	1	
3	5HD-12462-00	CAP, RADIATOR	1	1	1	1	
4	91A20-05065	TUBE, FLEXIBLE VINYL	1	1	1	1	
5	90467-09006	CLIP	1	1	1	1	
6	90480-15528	GROMMET	6	6	6	6	
7	90387-06065	COLLAR	6	6	6	6	
8	95027-06025	BOLT, FLANGE	6	6	6	6	
9	90201-06571	WASHER, PLATE	6	6	6	6	
10	5NL-12481-00	PIPE 1	1	1	1	1	
11	93210-15414	O-RING	1	1	1	1	
12	91317-06012	BOLT	1	1	1	1	
13	5SG-12576-00	HOSE 1	1	1	1	1	
14	5SG-12577-00	HOSE 2	1	1	1	1	
15	5SG-12578-00	HOSE 3	1	1	1	1	
16	5SG-12579-00	HOSE 4	1	1	1	1	
17	90450-25037	HOSE CLAMP ASSY	3	3	3	3	
18	90450-22017	HOSE CLAMP ASSY	4	4	4	4	
19	90450-32015	HOSE CLAMP ASSY	1	1	1	1	
20	95827-06010	BOLT, FLANGE	2	2	2	2	

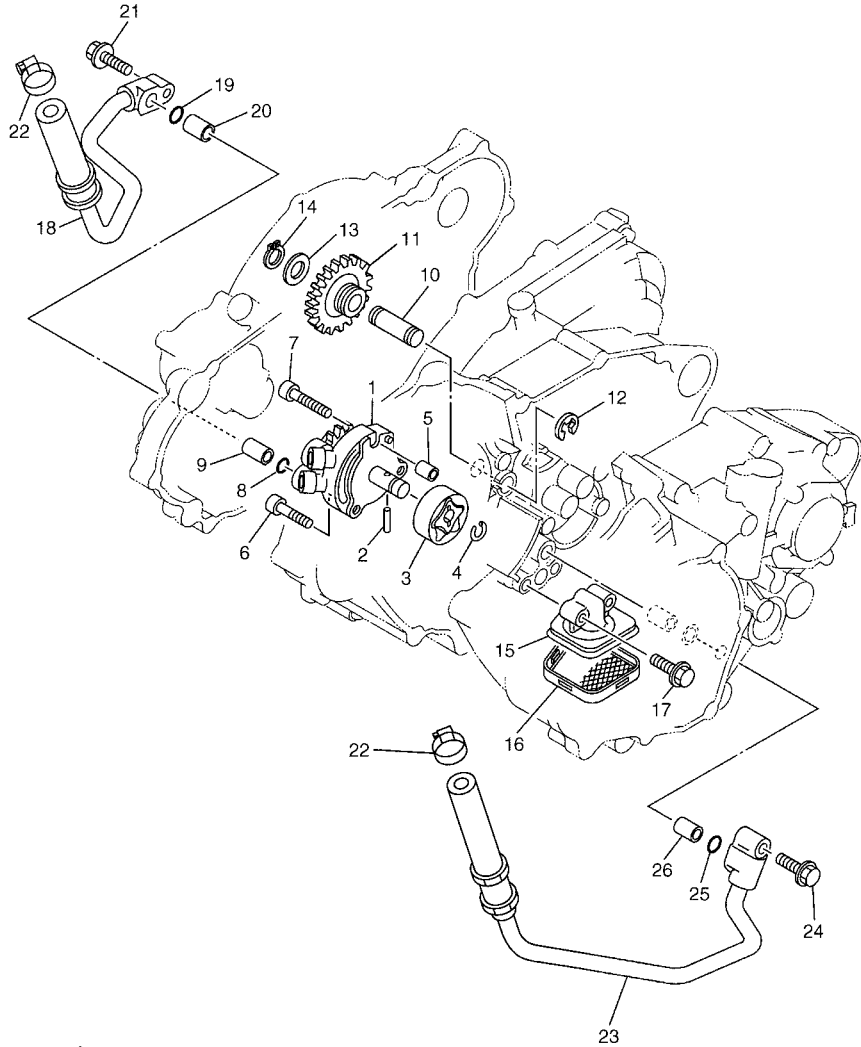

5UL1100-B070

FIG. 7 OIL PUMP

REF. NO.	PART NO.	DESCRIPTION	5XC1	5XC2	5XC3	5XC4	REMARKS
1	5SG-13300-00	OIL PUMP ASSY	1	1	1	1	
2	93603-16219	PIN, DOWEL	1	1	1	1	
3	5NL-13320-00	ROTOR ASSY 2	1	1	1	1	
4	93440-10153	CIRCLIP	1	1	1	1	
5	99530-08012	PIN, DOWEL	1	1	1	1	
6	90110-06058	BOLT, HEXAGON SOCKET HEAD	2	2	2	2	
7	91314-06030	BOLT	1	1	1	1	
8	93210-10197	O-RING	1	1	1	1	
9	99530-10114	PIN, DOWEL	1	1	1	1	
10	5BE-13342-00	SHAFT, IDLE GEAR	1	1	1	1	
11	5NL-13341-00	GEAR, OIL PUMP IDLE	1	1	1	1	
12	99001-08600	CIRCLIP	1	1	1	1	
13	90201-12166	WASHER, PLATE	1	1	1	1	
14	99009-12400	CIRCLIP	1	1	1	1	
15	5NL-13412-00	HOUSING, STRAINER	1	1	1	1	
16	5NL-13411-00	STRAINER, OIL	1	1	1	1	
17	95027-06025	BOLT, FLANGE	2	2	2	2	
18	5XC-13464-00	HOSE, OIL 1	1	1	1	1	
19	93210-10197	O-RING	1	1	1	1	
20	99530-10114	PIN, DOWEL	1	1	1	1	
21	95027-06025	BOLT, FLANGE	1	1	1	1	
22	90450-22017	HOSE CLAMP ASSY	2	2	2	2	
23	5XC-13465-00	HOSE, OIL 2	1	1	1	1	
24	95027-06025	BOLT, FLANGE	1	1	1	1	
25	93210-10197	O-RING	1	1	1	1	
26	99530-10114	PIN, DOWEL	1	1	1	1	

B10

FIG. 8 OIL CLEANER

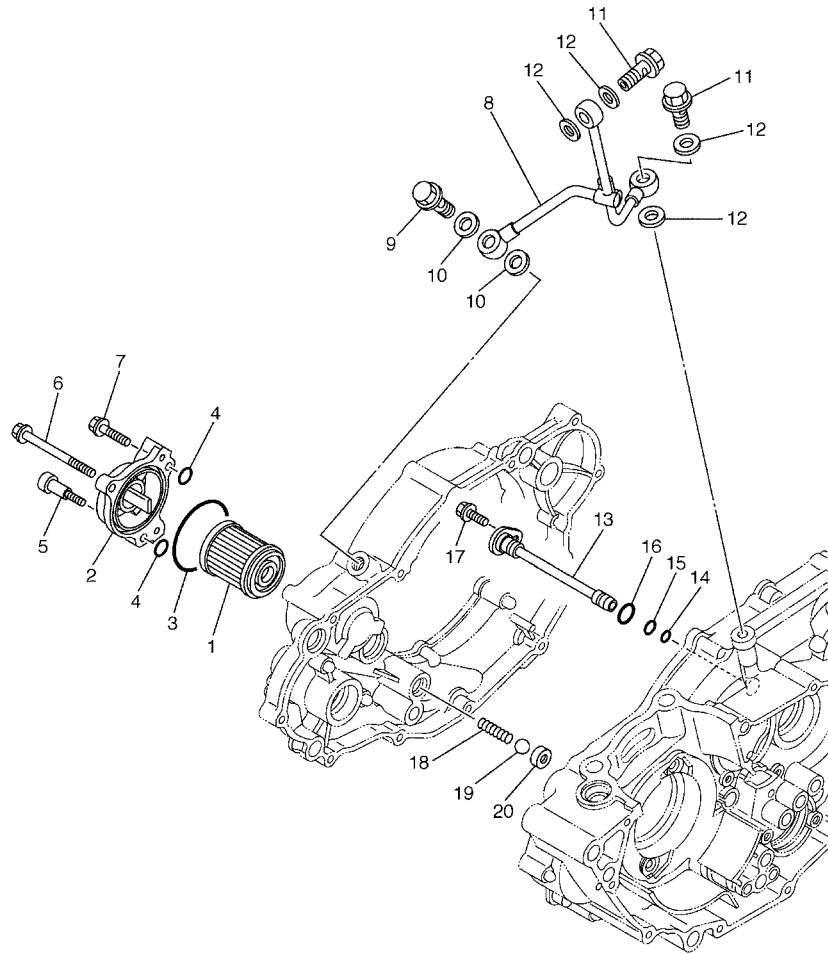

REF. NO.	PART NO.	DESCRIPTION	5XC1	5XC2	5XC3	5XC4	REMARKS
1	5TA-13440-00	ELEMENT ASSY, OIL CLEANER	1	1	1	1	
2	5BE-13447-10	COVER, OIL ELEMENT	1	1	1	1	
3	93210-47675	O-RING	1	1	1	1	
4	93210-07135	O-RING	3	3	3	3	
5	90109-065G2	BOLT	1	1	1	1	
6	95027-06065	BOLT, FLANGE	1	1	1	1	
7	95027-06025	BOLT, FLANGE	1	1	1	1	
8	5NL-13161-00	PIPE, DELIVERY 1	1	1	1	1	
9	90401-10159	BOLT, UNION	1	1	1	1	
10	90430-10188	GASKET	2	2	2	2	
11	90401-08038	BOLT, UNION	2	2	2	2	
12	90430-08119	GASKET	4	4	4	4	
13	5NL-13171-00	PIPE, DELIVERY 2	1	1	1	1	
14	93210-07003	O-RING	1	1	1	1	
15	93210-09008	O-RING	1	1	1	1	
16	93210-12759	O-RING	1	1	1	1	
17	95027-06012	BOLT, FLANGE	1	1	1	1	
18	90501-043E0	SPRING, COMPRESSION	1	1	1	1	
19	93503-08007	BALL	1	1	1	1	
20	583-13113-00	SEAT, CHECK BALL	1	1	1	1	

5XC1100-C080

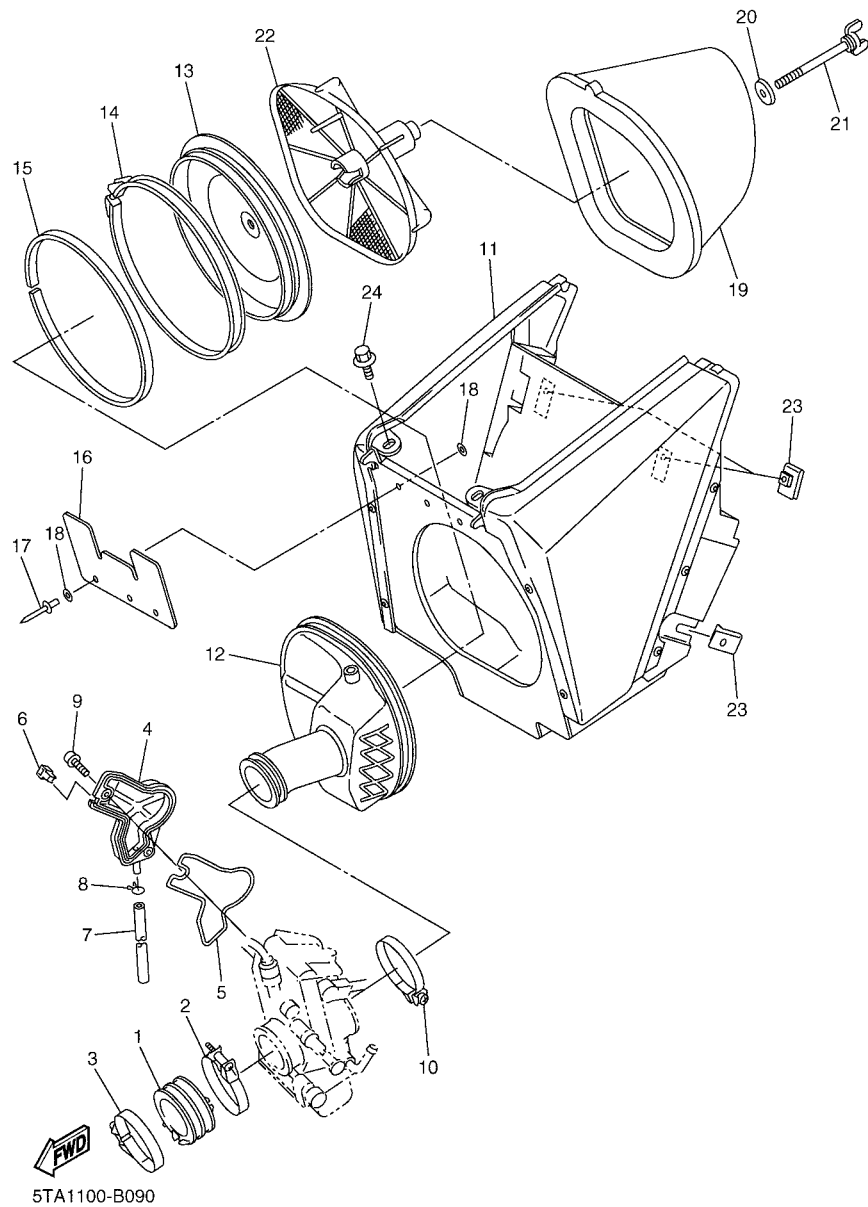
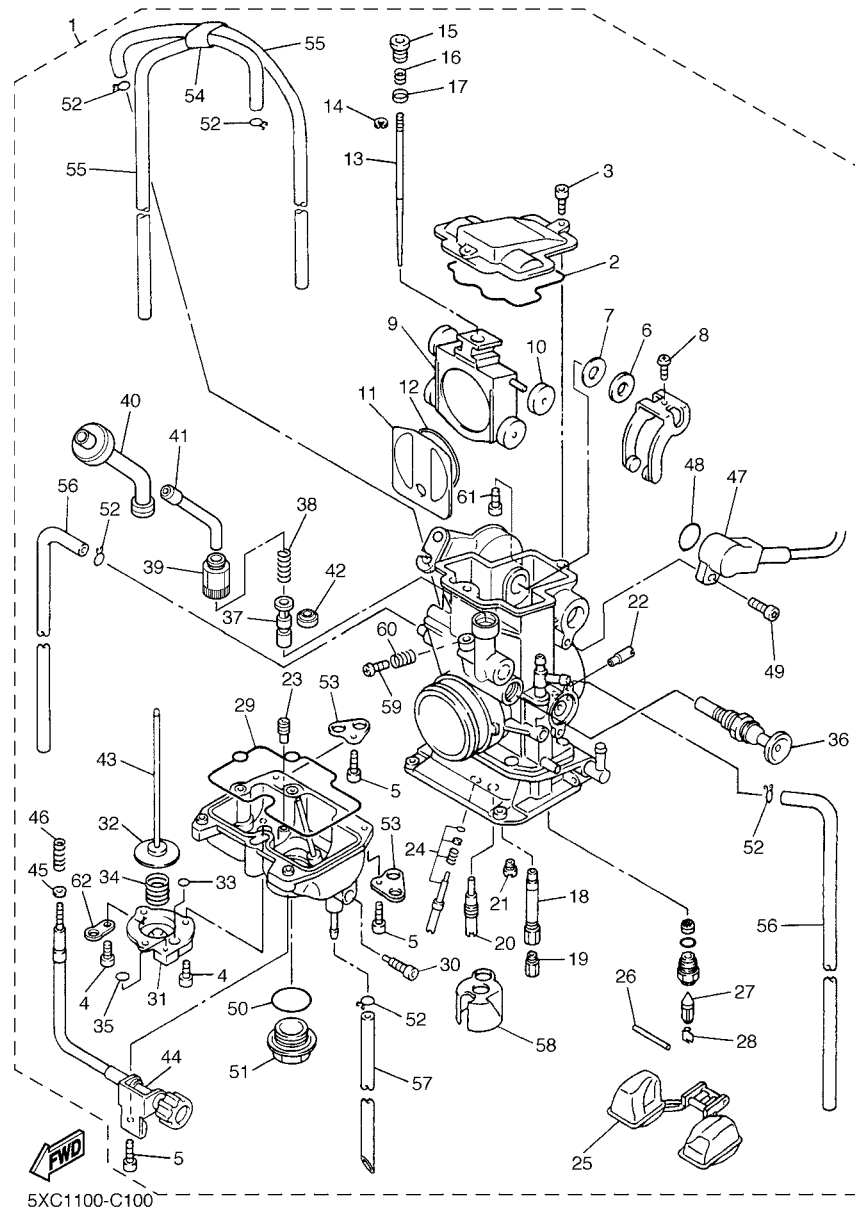

FIG. 9 INTAKE

REF. NO.	PART NO.	DESCRIPTION	5XC1	5XC2	5XC3	5XC4	REMARKS
1	5UL-13597-00	JOINT, CARBURETOR 3	1	1	1	1	
2	90450-57092	HOSE CLAMP ASSY	1	1	1	1	
3	90450-54002	HOSE CLAMP ASSY	1	1	1	1	
4	5TA-14293-00	COVER 1	1	1	1	1	
5	5TA-14227-00	GASKET	1	1	1	1	
6	5TA-14239-00	SEAL	1	1	1	1	
7	5TA-14987-00	HOSE	1	1	1	1	
8	3TJ-14137-40	CLIP	1	1	1	1	
9	5TA-14428-00	BOLT	2	2	2	2	
10	90450-61001	HOSE CLAMP ASSY	1	1	1	1	
11	5TA-14401-01	AIR CLEANER CASE ASSY	1	1	1	1	
12	5TA-14453-00	JOINT, AIR CLEANER 1	1	1	1	1	
13	5NY-14459-00	HOLDER, GUIDE	1	1	1	1	
14	5NY-14455-10	BAND	1	1	1	1	
15	5NY-14442-00	SPACER	1	1	1	1	
16	5XD-14417-00	COVER 1	1	1	1	1	
17	90267-32070	RIVET, BLIND	3	3	3	3	
18	90201-03313	WASHER, PLATE	6	6	6	6	
19	4XM-14451-00	ELEMENT, AIR CLEANER	1	1	1	1	
20	90209-06096	WASHER	1	1	1	1	
21	90122-06035	BOLT, WING	1	1	1	1	
22	5BE-14458-00	GUIDE	1	1	1	1	
23	90183-06023	NUT, SPRING	3	3	3	3	
24	90109-067F4	BOLT	2	2	2	2	



5XC1100-C100

FIG. 10 CARBURETOR

REF. NO.	PART NO.	DESCRIPTION	5XC1	5XC2	5XC3	5XC4	REMARKS
1	5XC-14101-00	CARBURETOR ASSY 1	1	1	1	1	
2	5JG-14959-00	.GASKET	1	1	1	1	
3	91316-04012	.BOLT	2	2	2	2	
4	688-14592-00	.SCREW	3	3	3	3	
5	98502-04012	.SCREW, PAN HEAD	4	4	4	4	
6	90202-08045	.WASHER, PLATE	1	1	1	1	
7	5JG-14951-00	.WASHER	1	1	1	1	
8	5JG-14522-00	.SCREW, ADJUST	1	1	1	1	
9	5JG-14388-00	.VALVE, VACUUM CONTROL	1	1	1	1	
10	3TJ-14267-40	.ROLLER	1	1	1	1	
11	5JG-14546-01	.VALVE, NEEDLE	1	1	1	1	
12	4FN-14997-00	.SEAL	1	1	1	1	
13	5JG-14916-ER	.NEEDLE (#OBEKR)	1	1	1	1	STD
	5JG-14916-EN	.NEEDLE (#OBEKN)	1	1	1	1	AP
	5JG-14916-EP	.NEEDLE (#OBEKP)	1	1	1	1	AP
	5JG-14916-E1	.NEEDLE (#OBEKQ)	1	1	1	1	AP
	5JG-14916-ES	.NEEDLE (#OBEKS)	1	1	1	1	AP
	5JG-14916-ET	.NEEDLE (#OBEKT)	1	1	1	1	AP
	5JG-14916-EU	.NEEDLE (#OBEKU)	1	1	1	1	AP
14	3TJ-14159-40	.CLIP	1	1	1	1	
15	5JG-14521-00	.SCREW, ADJUST	1	1	1	1	
16	5JG-14275-00	.SPRING	1	1	1	1	
17	5JG-14264-00	.COLLAR	1	1	1	1	
18	5JG-14947-00	.NOZZLE, MAIN	1	1	1	1	
19	4MX-14943-43	.JET, MAIN (#180)	1	1	1	1	STD
	4MX-14943-41	.JET, MAIN (#170)	1	1	1	1	AP
	4MX-14943-92	.JET, MAIN (#172)	1	1	1	1	AP

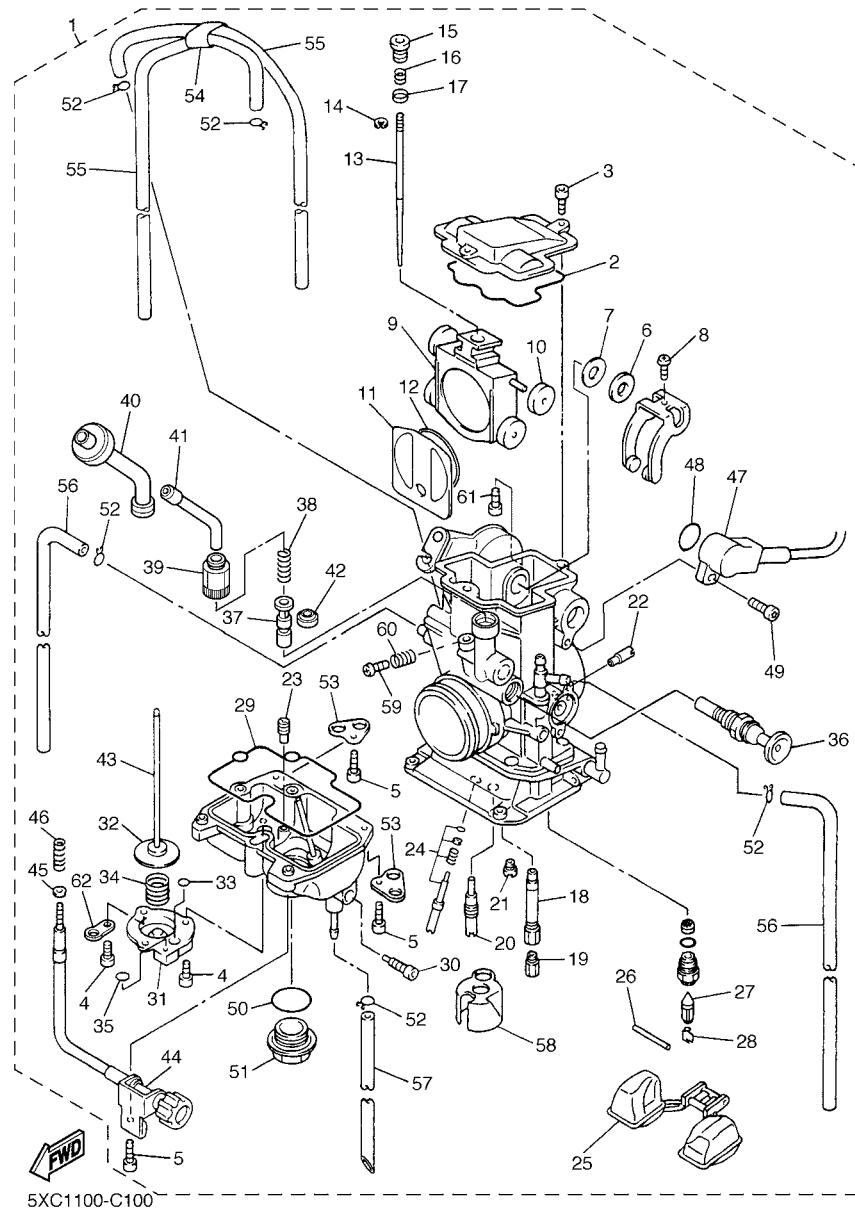
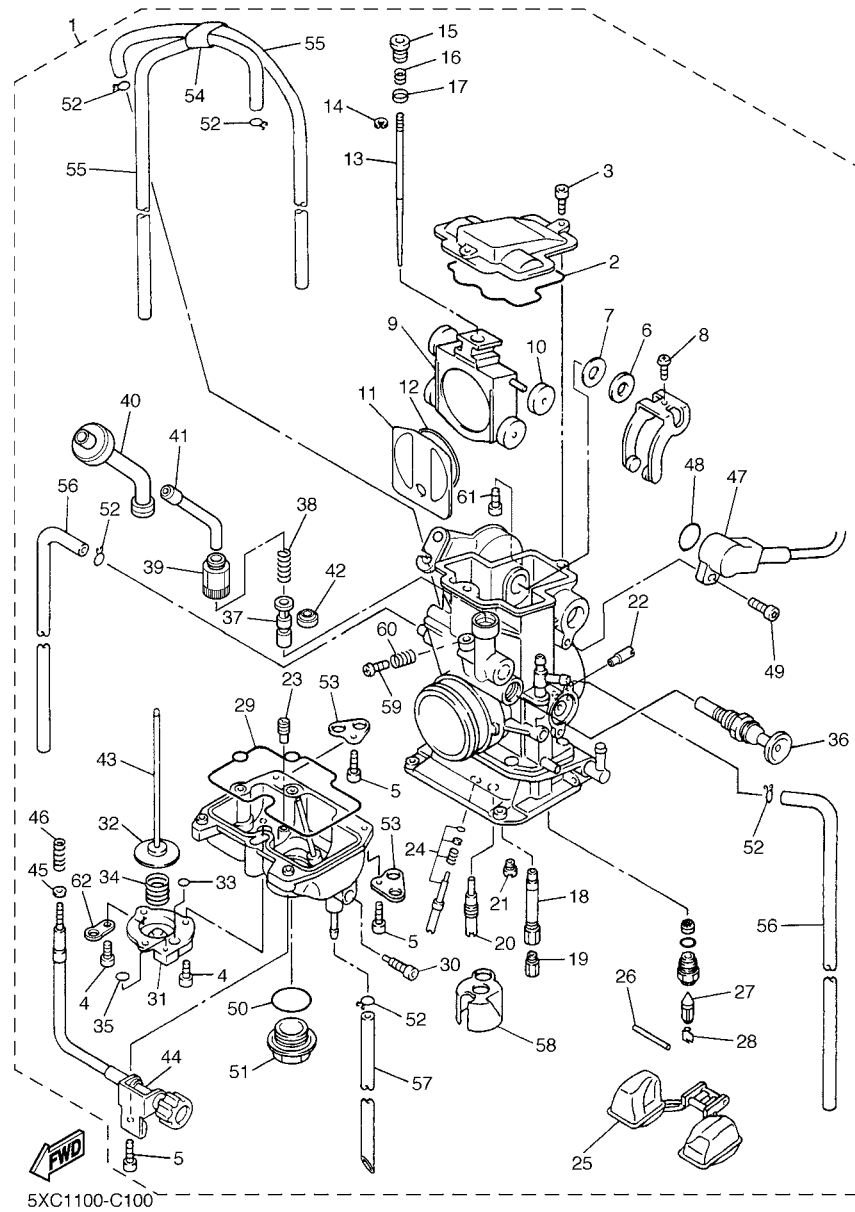

FIG. 10 CARBURETOR

REF. NO.	PART NO.	DESCRIPTION	5XC1	5XC2	5XC3	5XC4	REMARKS
19	4MX-14943-42	.JET, MAIN (#175)	1	1	1	1	AP
	4MX-14943-93	.JET, MAIN (#178)	1	1	1	1	AP
	4MX-14943-94	.JET, MAIN (#182)	1	1	1	1	AP
	4MX-14943-44	.JET, MAIN (#185)	1	1	1	1	AP
	4MX-14943-95	.JET, MAIN (#188)	1	1	1	1	AP
	4MX-14943-45	.JET, MAIN (#190)	1	1	1	1	AP
20	4MX-14948-04	.JET, SLOW (#42)	1	1	1	1	STD
	4MX-14948-02	.JET, SLOW (#38)	1	1	1	1	AP
	4MX-14948-03	.JET, SLOW (#40)	1	1	1	1	AP
	4MX-14948-05	.JET, SLOW (#45)	1	1	1	1	AP
	4MX-14948-06	.JET, SLOW (#48)	1	1	1	1	AP
21	3TJ-1494F-16	.JET (#72)	1	1	1	1	STD
	3TJ-1494F-13	.JET (#65)	1	1	1	1	AP
	3TJ-1494F-14	.JET (#68)	1	1	1	1	AP
	3TJ-1494F-15	.JET (#70)	1	1	1	1	AP
	3TJ-1494F-17	.JET (#75)	1	1	1	1	AP
	3TJ-1494F-18	.JET (#78)	1	1	1	1	AP
	3TJ-1494F-19	.JET (#80)	1	1	1	1	AP
22	5TA-14943-27	.JET, MAIN (#100)	1	1	1	1	
23	4JT-1494F-23	.JET (#90)	1	1	1	1	STD
	4JT-1494F-11	.JET (#60)	1	1	1	1	AP
	4JT-1494F-15	.JET (#70)	1	1	1	1	AP
	4JT-1494F-19	.JET (#80)	1	1	1	1	AP
	4JT-1494F-27	.JET(#100)	1	1	1	1	AP
	4JT-1494F-29	.JET(#110)	1	1	1	1	AP
	4JT-1494F-31	.JET(#120)	1	1	1	1	AP
24	3TJ-14105-40	.PILOT SCREW SET	1	1	1	1	



5XC1100-C100

FIG. 10 CARBURETOR

REF. NO.	PART NO.	DESCRIPTION	5XC1	5XC2	5XC3	5XC4	REMARKS
25	4SR-14985-00	.FLOAT	1	1	1	1	
26	676-14548-00	.PIN, FLOAT ARM	1	1	1	1	
27	4MX-14392-00	.VALVE, NEEDLE	1	1	1	1	
28	633-14159-00	.CLIP	1	1	1	1	
29	5JG-14984-00	.GASKET, FLOAT CHAMBER	1	1	1	1	
30	3TJ-14191-40	.PLUG, DRAIN	1	1	1	1	
31	3TJ-14293-40	.COVER 1	1	1	1	1	
32	5JG-14940-76	.DIAPHRAGM ASSY	1	1	1	1	STD
	5JG-14940-16	.DIAPHRAGM ASSY	1	1	1	1	AP
	5JG-14940-17	.DIAPHRAGM ASSY	1	1	1	1	AP
	5JG-14940-18	.DIAPHRAGM ASSY	1	1	1	1	AP
33	3TJ-14536-40	.GASKET	1	1	1	1	
34	3TJ-14933-40	.SPRING, DIAPHRAGM	1	1	1	1	
35	6H4-14561-00	.O-RING	1	1	1	1	
36	5TA-14171-00	.PLUNGER, STARTER	1	1	1	1	
37	5TA-14371-00	.PLUNGER, STARTER	1	1	1	1	
38	5TA-14335-00	.SPRING, PLUNGER	1	1	1	1	
39	5TA-14991-00	.SCREW	1	1	1	1	
40	5TA-14374-00	.CAP, PLUNGER	1	1	1	1	
41	5TA-14155-00	.GUIDE, CABLE	1	1	1	1	
42	5TA-14997-00	.SEAL	1	1	1	1	
43	5JG-14379-00	.ROD, STARTER	1	1	1	1	
44	5JG-14922-00	.SCREW, THROTTLE	1	1	1	1	
45	90201-08410	.WASHER, PLATE	1	1	1	1	
46	5TA-14934-00	.SPRING, THROTTLE STOP	1	1	1	1	
47	5TA-85885-00	.THROTTLE SENSOR ASSY	1	1	1	1	
48	5NX-14562-00	.O-RING	1	1	1	1	

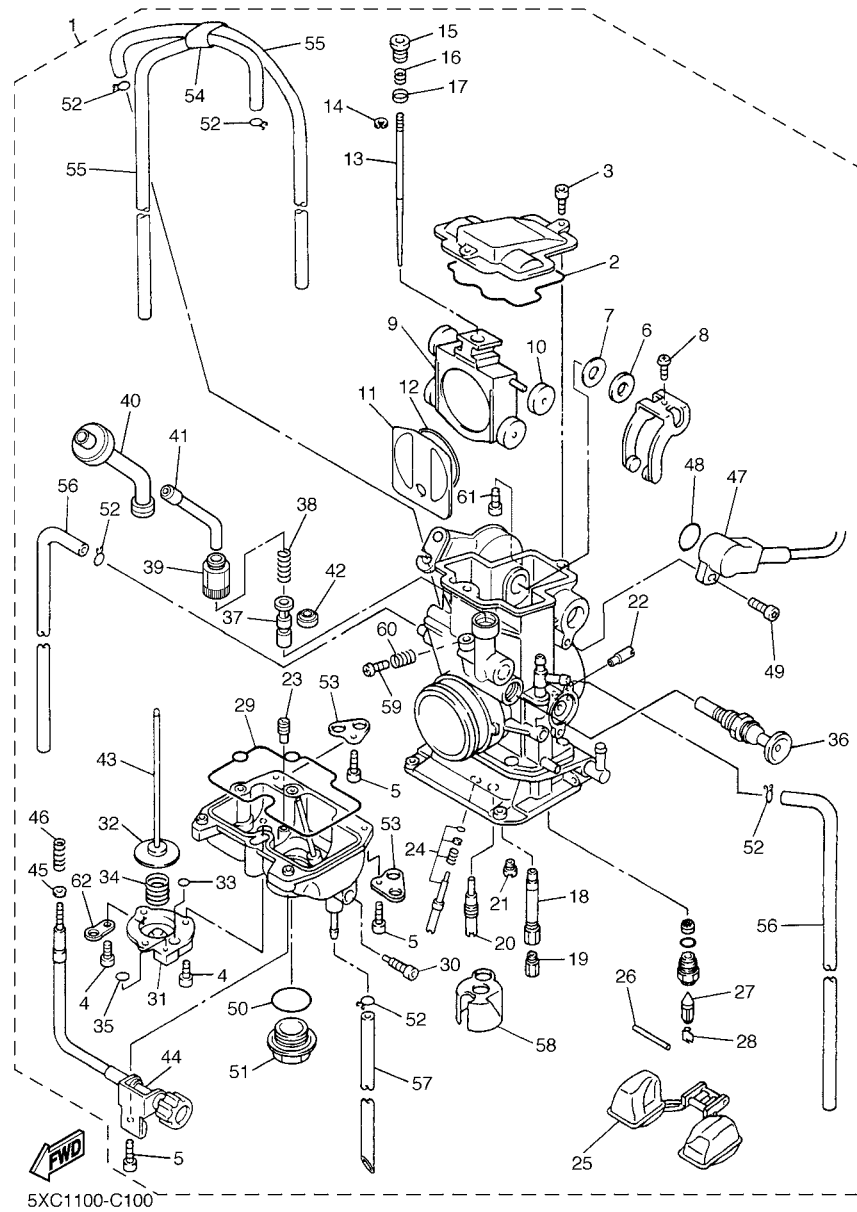

FIG. 10 CARBURETOR

REF. NO.	PART NO.	DESCRIPTION	5XC1	5XC2	5XC3	5XC4	REMARKS
49	5NX-14216-00	.SCREW	1	1	1	1	
50	4MX-14561-00	.O-RING	1	1	1	1	
51	4MX-14115-00	.PLUG, SCREW	1	1	1	1	
52	3TJ-14137-40	.CLIP	5	5	5	5	
53	5BE-14146-00	.PLATE	2	2	2	2	
54	5TA-14261-00	.HOLDER	1	1	1	1	
55	5TA-14196-00	.PIPE	2	2	2	2	
56	5TA-14197-00	.PIPE	2	2	2	2	
57	5TJ-14987-00	.HOSE	1	1	1	1	
58	5JG-14346-00	.PLATE	1	1	1	1	
59	5JG-14565-00	.SCREW	1	1	1	1	
60	5JG-14531-00	.SPRING, ADJUST SCREW	1	1	1	1	
61	5JG-14591-00	.SCREW	1	1	1	1	
62	5PA-14146-00	.PLATE	1	1	1	1	

EXCEPT FOR USA

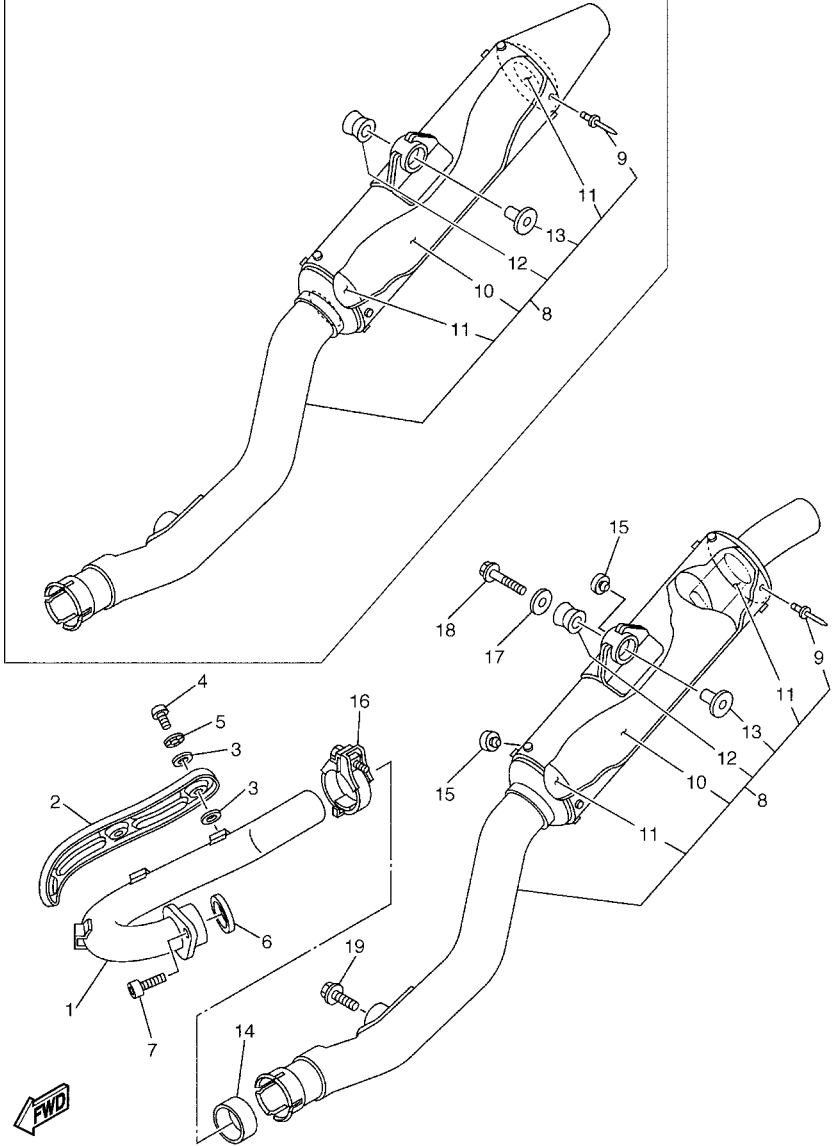
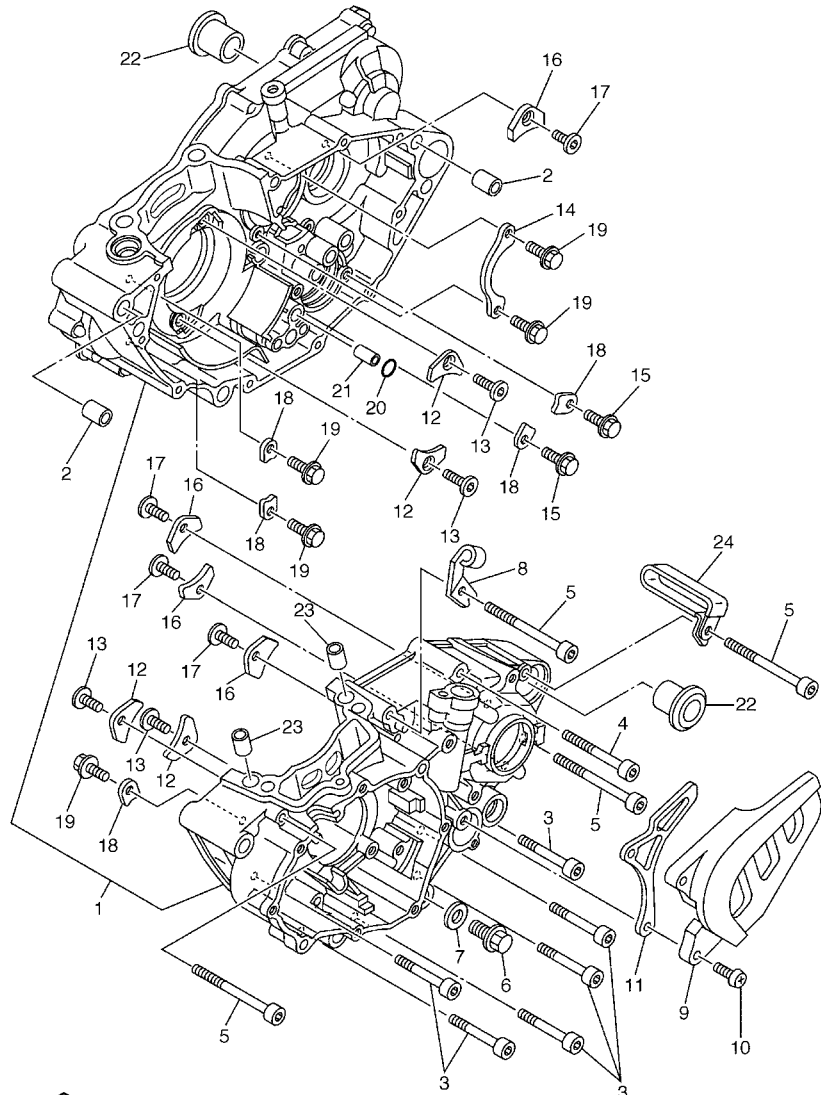

FIG. 11 EXHAUST

REF. NO.	PART NO.	DESCRIPTION	5XC1	5XC2	5XC3	5XC4	REMARKS
1	5XC-14611-00	PIPE, EXHAUST 1	1	1	1	1	
2	5XC-14628-00	PROTECTOR, EXHAUST PIPE	1	1	1	1	
3	4BD-14766-00	WASHER, PROTECTOR	6	6	6	6	
4	98980-06008	SCREW, BIND	3	3	3	3	
5	90206-06090	WASHER, WAVE	3	3	3	3	
6	5NL-14613-00	GASKET, EXHAUST PIPE	1	1	1	1	
7	91317-08020	BOLT	1	1	1	1	
8	5UL-Y1475-11	SILENCER ASSY				1	
9	90267-48121	.RIVET, BLIND	16	16	16	16	
10	5NL-1469A-00	.FIBER	1	1	1	1	
11	5BE-1469E-00	.FIBER	2	2	2	2	
12	5BE-14747-00	.DAMPER, MUFFLER	1	1	1	1	
13	90387-0814J	.COLLAR	1	1	1	1	
14	3VD-14755-00	GASKET, SILENCER	1	1	1	1	
15	22W-24181-00	DAMPER, LOCATING 1	2	2	2	2	
16	5UL-14788-00	BAND, SILENCER	1	1	1	1	
17	90201-081R9	WASHER, PLATE	1	1	1	1	
18	95817-08030	BOLT, FLANGE	1	1	1	1	
19	90105-08057	BOLT, FLANGE	1	1	1	1	



5XC1100-C120

FIG. 12 CRANKCASE

REF. NO.	PART NO.	DESCRIPTION	5XC1	5XC2	5XC3	5XC4	REMARKS
1	5XC-15150-00	CRANKCASE ASSY	1	1	1	1	
2	93612-16254	PIN, DOWEL	2	2	2	2	
3	91317-06045	BOLT	6	6	6	6	
4	91317-06055	BOLT	1	1	1	1	
5	91317-06070	BOLT	4	4	4	4	
6	95027-10016	BOLT, FLANGE	1	1	1	1	
7	90430-10188	GASKET	1	1	1	1	
8	5NL-15441-01	HOLDER, CLUTCH CABLE	1	1	1	1	
9	5BE-15421-01	COVER, CRANKCASE 2	1	1	1	1	
10	98507-06025	SCREW, PAN HEAD	2	2	2	2	
11	5NL-17466-00	GUIDE, CHAIN	1	1	1	1	
12	5BE-15383-01	PLATE, BEARING COVER	4	4	4	4	
13	90149-06126	SCREW	4	4	4	4	
14	5NL-15388-00	PLATE, BEARING COVER	1	1	1	1	
15	90105-06553	BOLT, FLANGE	2	2	2	2	
16	4JT-15381-01	PLATE, BEARING COVER	4	4	4	4	
17	90149-06326	SCREW	4	4	4	4	
18	5DH-18562-00	PLATE, STOPPER 2	5	5	5	5	
19	90105-06553	BOLT, FLANGE	5	5	5	5	
20	93210-10197	O-RING	1	1	1	1	
21	99530-10114	PIN, DOWEL	1	1	1	1	
22	90387-18007	COLLAR	2	2	2	2	
23	99530-10116	PIN, DOWEL	2	2	2	2	
24	90465-10013	CLAMP	1	1	1	1	

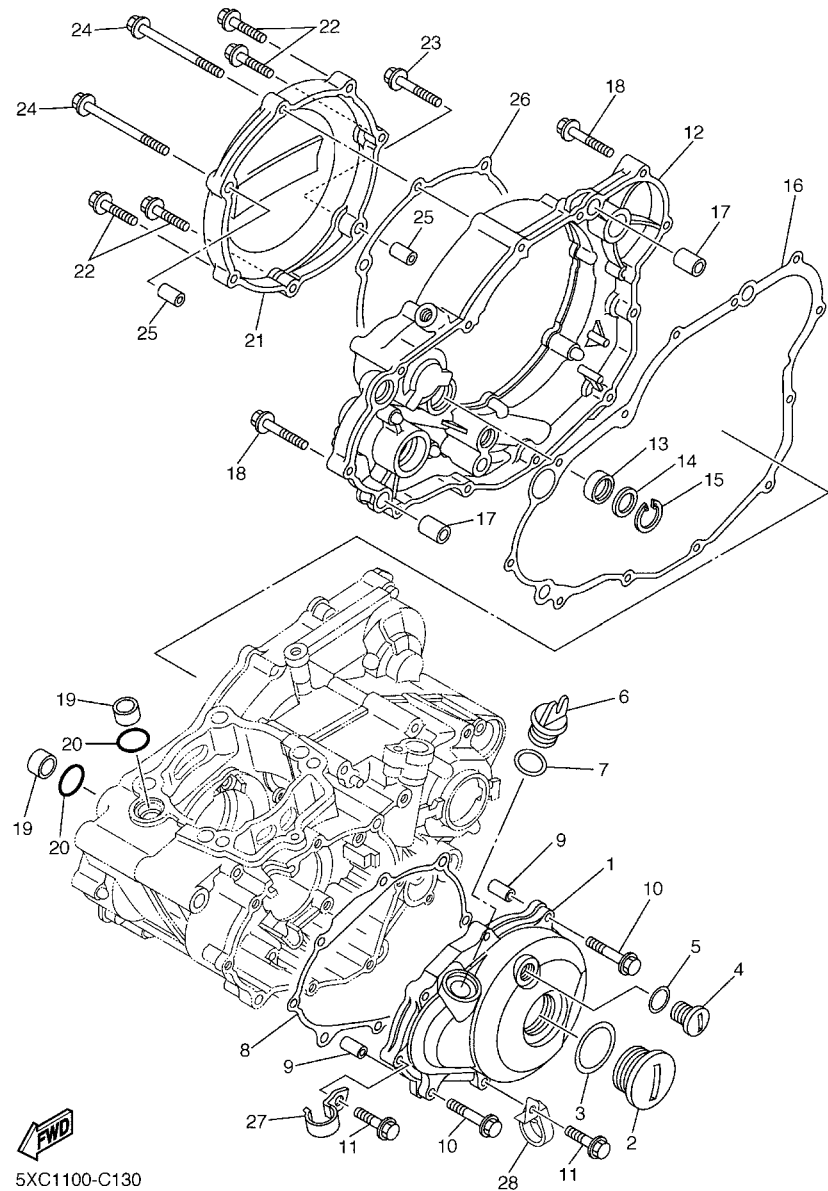

5XC1100-C130

FIG. 13 CRANKCASE COVER 1

REF. NO.	PART NO.	DESCRIPTION	5XC1	5XC2	5XC3	5XC4	REMARKS
1	5NL-15411-10	COVER, CRANKCASE 1	1	1	1	1	
2	90340-32123	PLUG, STRAIGHT SCREW	1	1	1	1	
3	93210-32172	O-RING	1	1	1	1	
4	90340-14128	PLUG, STRAIGHT SCREW	1	1	1	1	
5	93210-14369	O-RING	1	1	1	1	
6	3Y1-15363-00	PLUG, OIL	1	1	1	1	
7	93210-19123	O-RING	1	1	1	1	
8	5NL-15451-00	GASKET, CRANKCASE COVER 1	1	1	1	1	
9	99530-08016	PIN, DOWEL	2	2	2	2	
10	95027-06035	BOLT, FLANGE	2	2	2	2	
11	95027-06025	BOLT, FLANGE	6	6	6	6	
12	5NL-15431-10	COVER, CRANKCASE 3	1	1	1	1	
13	93101-14164	OIL SEAL	1	1	1	1	
14	90201-15701	WASHER, PLATE (T=1.0)	1	1	1	1	
15	99009-22500	CIRCLIP	1	1	1	1	
16	5NL-15462-00	GASKET, CRANKCASE COVER 3	1	1	1	1	
17	91812-16001	PIN, DOWEL	2	2	2	2	
18	95027-06035	BOLT, FLANGE	8	8	8	8	
19	5NL-12564-00	PIPE, WATER	2	2	2	2	
20	93210-16716	O-RING	2	2	2	2	
21	5NL-15415-00	COVER 1	1	1	1	1	
22	95027-06025	BOLT, FLANGE	4	4	4	4	
23	95027-06035	BOLT, FLANGE	1	1	1	1	
24	90105-065A1	BOLT, FLANGE	2	2	2	2	
25	99530-08016	PIN, DOWEL	2	2	2	2	
26	5NL-15453-00	GASKET 1	1	1	1	1	
27	90465-08029	CLAMP	1	1	1	1	

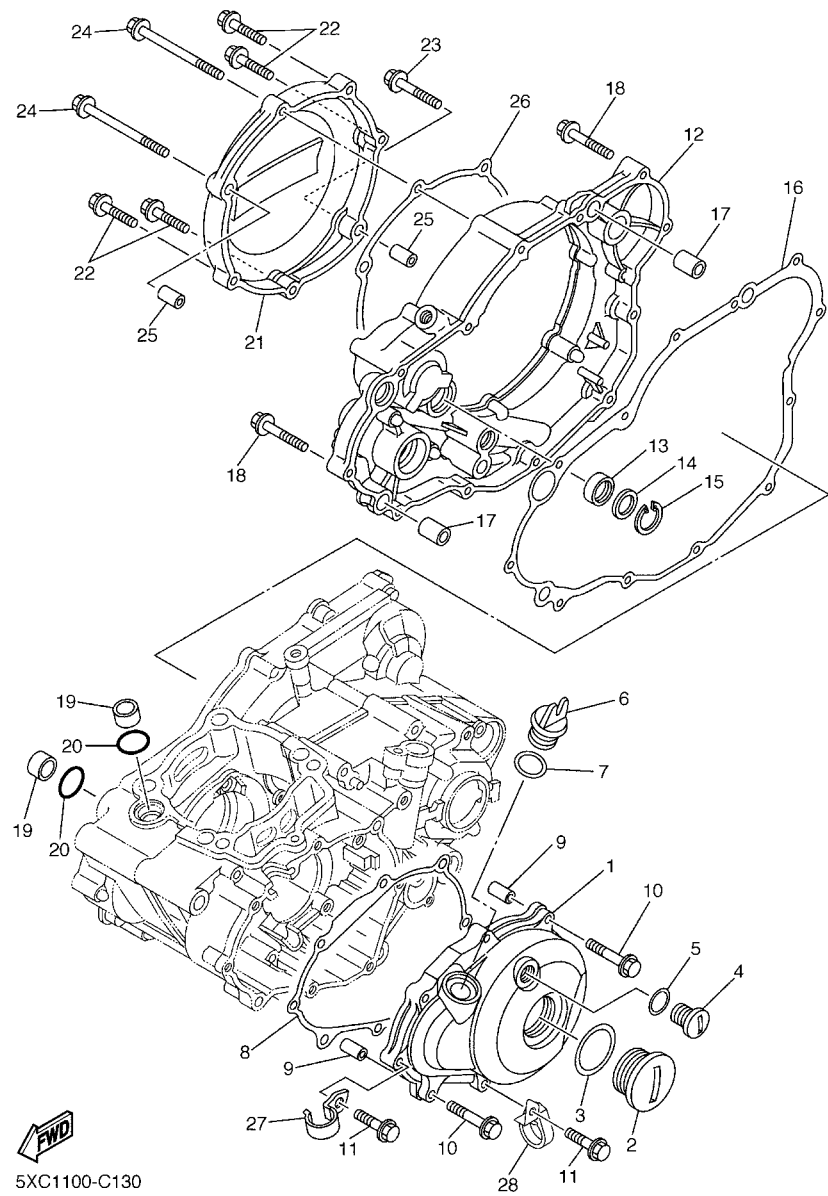

FWD
5XC1100-C130

FIG. 13 CRANKCASE COVER 1

REF. NO.	PART NO.	DESCRIPTION	5XC1	5XC2	5XC3	5XC4	REMARKS
28	5XD-15378-00	HOLDER	1	1	1	1	

FIG. 14 STARTER

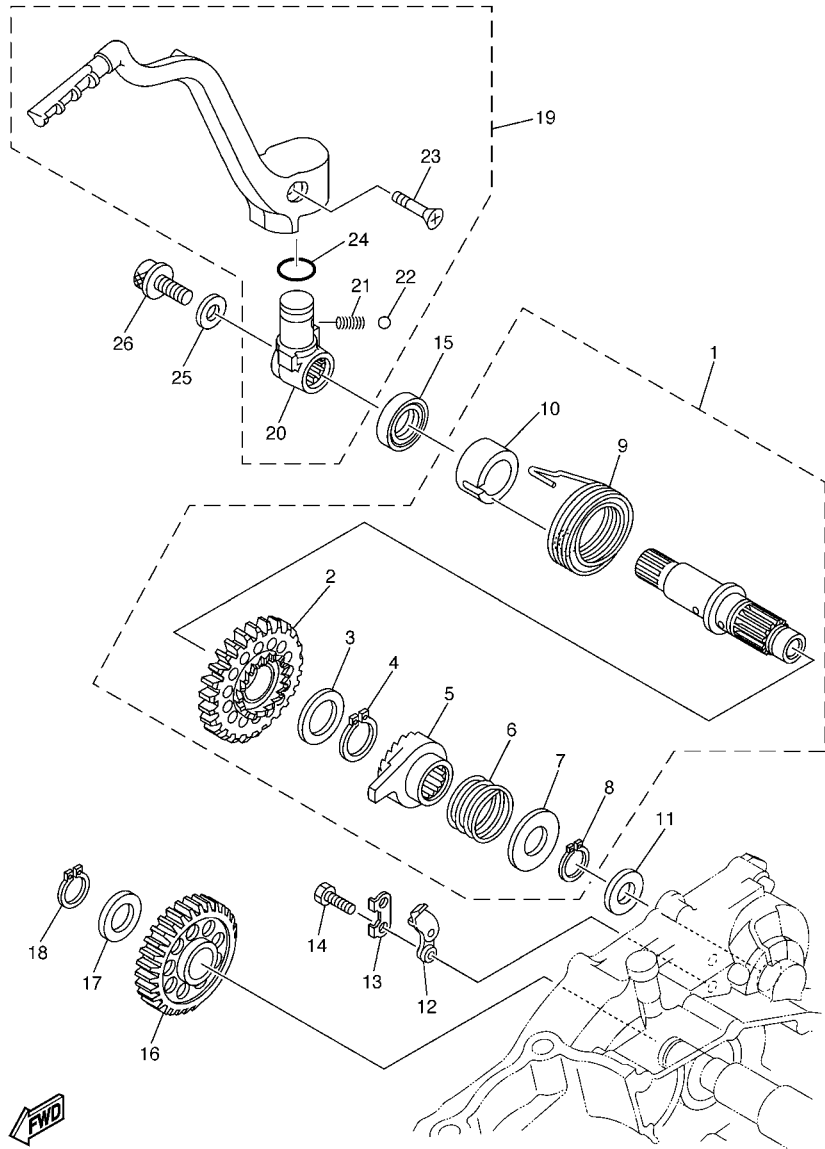

5SG1100-2140

REF. NO.	PART NO.	DESCRIPTION	5XC1	5XC2	5XC3	5XC4	REMARKS
1	5NL-15601-00	KICK SHAFT ASSY	1	1	1	1	
2	5NL-15641-00	.GEAR, KICK	1	1	1	1	
3	90201-20685	.WASHER, PLATE (T=0.5)	1	1	1	1	
4	93410-20038	.CIRCLIP	1	1	1	1	
5	4GY-15671-00	.WHEEL, RATCHET	1	1	1	1	
6	90501-16016	.SPRING, COMPRESSION	1	1	1	1	
7	90201-167P7	.WASHER, PLATE	1	1	1	1	
8	99009-16400	.CIRCLIP	1	1	1	1	
9	90508-30743	.SPRING, TORSION	1	1	1	1	
10	5NL-15664-00	.GUIDE, SPRING	1	1	1	1	
11	90201-162H4	WASHER, PLATE	1	1	1	1	
12	5SG-15668-00	STOPPER	1	1	1	1	
13	214-15686-00	WASHER, LOCK	1	1	1	1	
14	90101-06001	BOLT	2	2	2	2	
15	93102-18278	OIL SEAL	1	1	1	1	
16	5NL-15651-00	GEAR, KICK IDLE	1	1	1	1	
17	90201-177G4	WASHER, PLATE	1	1	1	1	
18	99009-17400	CIRCLIP	1	1	1	1	
19	5NL-15620-10	KICK CRANK ASSY	1	1	1	1	
20	5NX-15621-10	.BOSS, KICK CRANK	1	1	1	1	
21	90501-147A5	.SPRING, COMPRESSION	1	1	1	1	
22	93507-32009	.BALL	1	1	1	1	
23	90152-06010	.SCREW, COUNTERSUNK	1	1	1	1	
24	93210-17570	.O-RING	1	1	1	1	
25	90201-08326	WASHER, PLATE	1	1	1	1	
26	90109-082G0	BOLT	1	1	1	1	

FIG. 15 CLUTCH

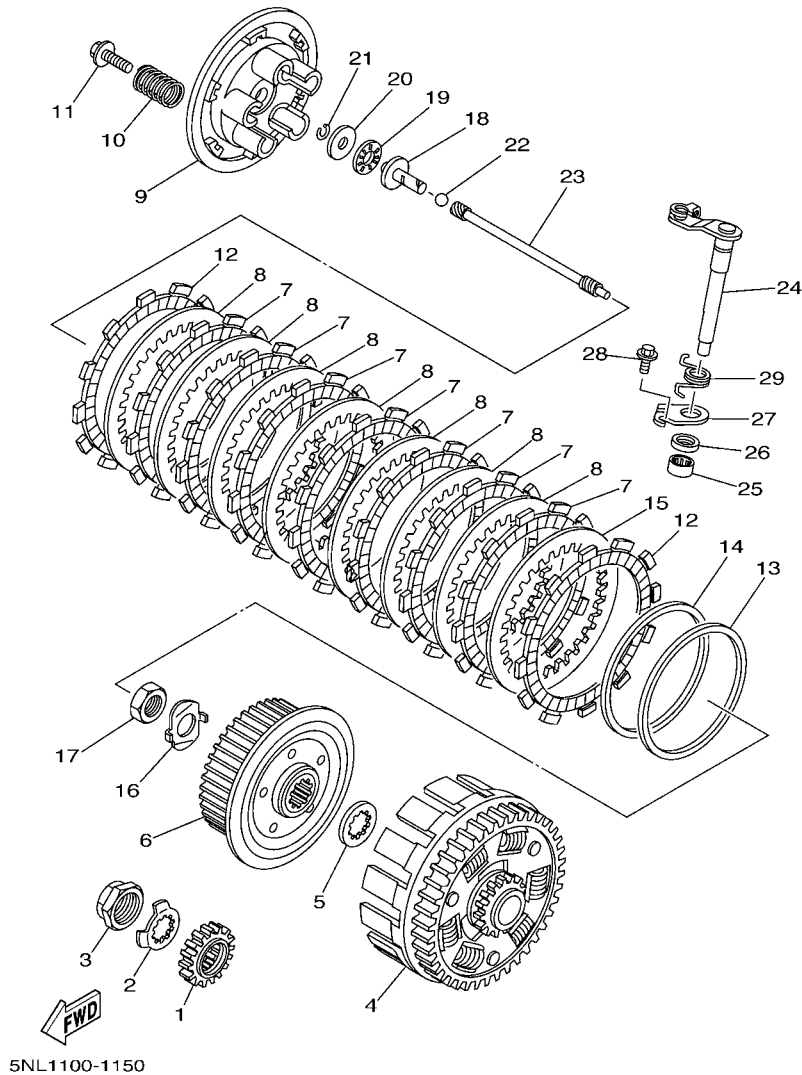

REF. NO.	PART NO.	DESCRIPTION	5XC1	5XC2	5XC3	5XC4	REMARKS
1	5NL-16111-00	GEAR, PRIMARY DRIVE	1	1	1	1	
2	90215-20003	WASHER, LOCK	1	1	1	1	
3	90179-18001	NUT	1	1	1	1	
4	5NL-16150-10	PRIMARY DRIVEN GEAR COMP.	1	1	1	1	
5	5NL-16154-00	PLATE, THRUST 1	1	1	1	1	
6	5NL-16371-00	BOSS, CLUTCH	1	1	1	1	
7	5DH-16321-00	PLATE, FRICTION	7	7	7	7	
8	5NL-16325-00	PLATE, CLUTCH 2	7	7	7	7	
9	5HD-16351-00	PLATE, PRESSURE 1	1	1	1	1	
10	90501-224J9	SPRING, COMPRESSION	5	5	5	5	(PINK)
11	90159-06092	SCREW, WITH WASHER	5	5	5	5	
12	3XJ-16321-00	PLATE, FRICTION	2	2	2	2	
13	5NL-16384-00	PLATE, SEAT	1	1	1	1	
14	5NL-16383-10	SPRING, CLUTCH BOSS	1	1	1	1	
15	5NL-16325-10	PLATE, CLUTCH 2	1	1	1	1	
16	90215-16289	WASHER, LOCK	1	1	1	1	
17	90170-16326	NUT	1	1	1	1	
18	5NL-16356-00	ROD, PUSH 1	1	1	1	1	
19	93340-21008	BEARING	1	1	1	1	
20	90201-080H1	WASHER, PLATE	1	1	1	1	
21	93440-07182	CIRCLIP	1	1	1	1	
22	93511-32027	BALL	1	1	1	1	
23	5NL-16357-00	ROD, PUSH 2	1	1	1	1	
24	5JG-16381-00	PUSH LEVER COMP.	1	1	1	1	
25	93317-11287	BEARING	1	1	1	1	
26	93102-12224	OIL SEAL	1	1	1	1	
27	4JT-16384-00	PLATE, SEAT	1	1	1	1	

FIG. 15 CLUTCH

REF. NO.	PART NO.	DESCRIPTION	5XC1	5XC2	5XC3	5XC4	REMARKS
28	95027-06010	BOLT, FLANGE	1	1	1	1	
29	90508-142B5	SPRING, TORSION	1	1	1	1	

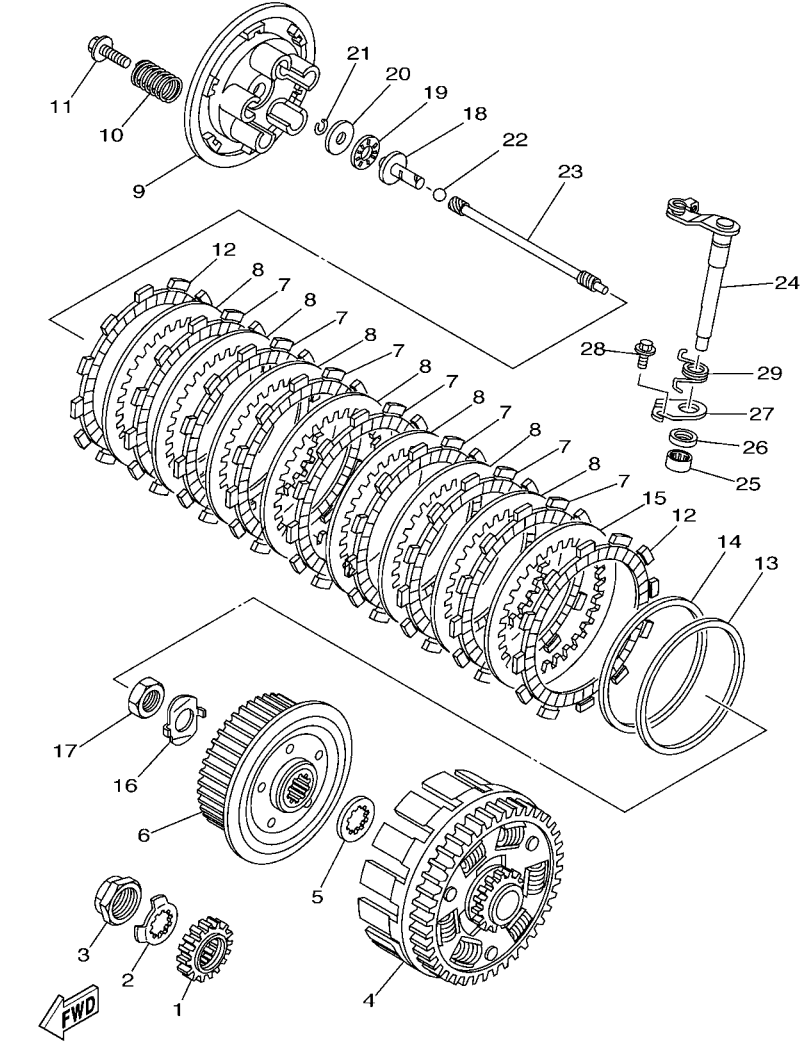

5NL1100-1150

FIG. 16 TRANSMISSION

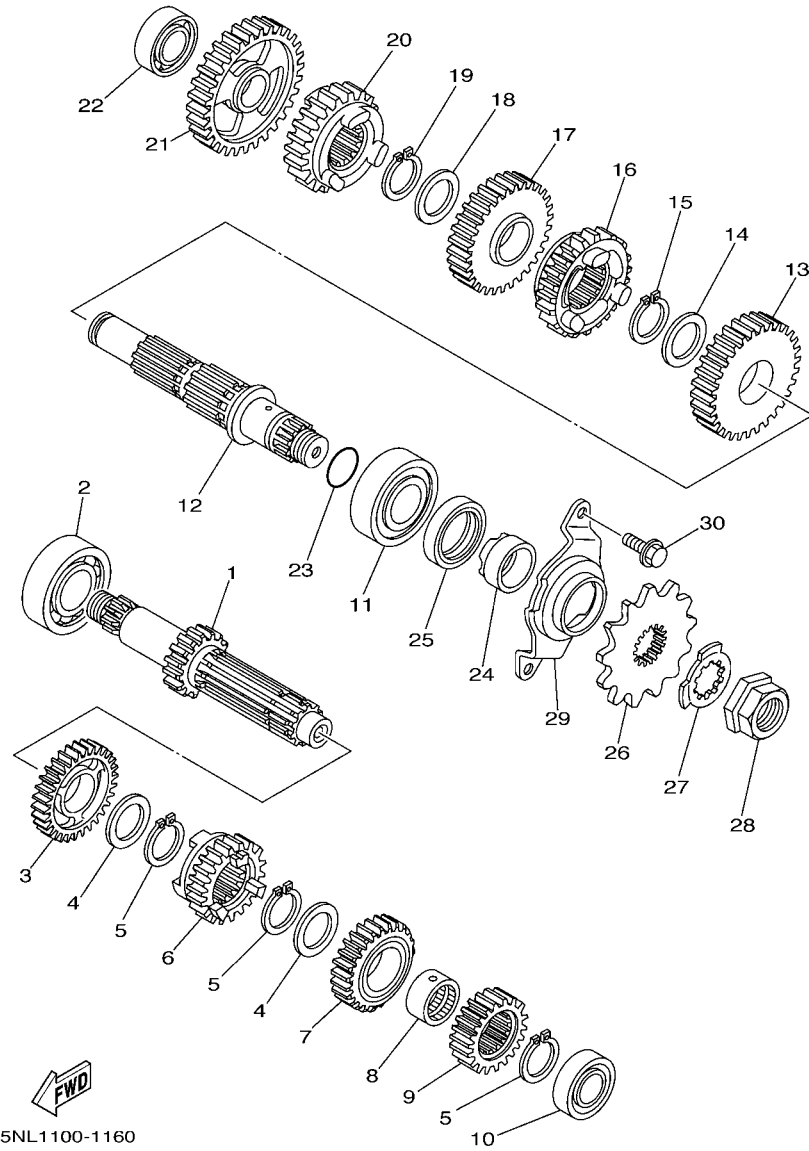

REF. NO.	PART NO.	DESCRIPTION	5XC1	5XC2	5XC3	5XC4	REMARKS
1	5NL-17411-10	AXLE,MAIN (14T)	1	1	1	1	
2	93306-20447	BEARING	1	1	1	1	
3	5NL-17151-00	GEAR, 5TH PINION (24T)	1	1	1	1	
4	90209-20008	WASHER	2	2	2	2	
5	93410-22039	CIRCLIP	3	3	3	3	
6	5NL-17131-10	GEAR, 3RD PINION (20T)	1	1	1	1	
7	5NL-17141-10	GEAR, 4TH PINION (22T)	1	1	1	1	
8	90387-20006	COLLAR	1	1	1	1	
9	5NL-17121-00	GEAR, 2ND PINION (16T)	1	1	1	1	
10	93306-00320	BEARING	1	1	1	1	
11	93306-27208	BEARING	1	1	1	1	
12	5NL-17402-00	DRIVE AXLE ASSY	1	1	1	1	
13	5NL-17221-00	GEAR, 2ND WHEEL (28T)	1	1	1	1	
14	90209-23012	WASHER	1	1	1	1	
15	93410-26067	CIRCLIP	1	1	1	1	
16	5NL-17241-10	GEAR, 4TH WHEEL (27T)	1	1	1	1	
17	5NL-17231-10	GEAR, 3RD WHEEL (29T)	1	1	1	1	
18	90209-20008	WASHER	1	1	1	1	
19	93410-22039	CIRCLIP	1	1	1	1	
20	5NL-17251-10	GEAR, 5TH WHEEL (25T)	1	1	1	1	
21	5NL-17211-10	GEAR, 1ST WHEEL (30T)	1	1	1	1	
22	93306-00317	BEARING	1	1	1	1	
23	93210-196A4	O-RING	1	1	1	1	
24	90387-22001	COLLAR	1	1	1	1	
25	93102-28010	OIL SEAL	1	1	1	1	
26	9383B-13218	SPROCKET, DRIVE (13T)	1	1	1	1	
27	90215-20003	WASHER, LOCK	1	1	1	1	

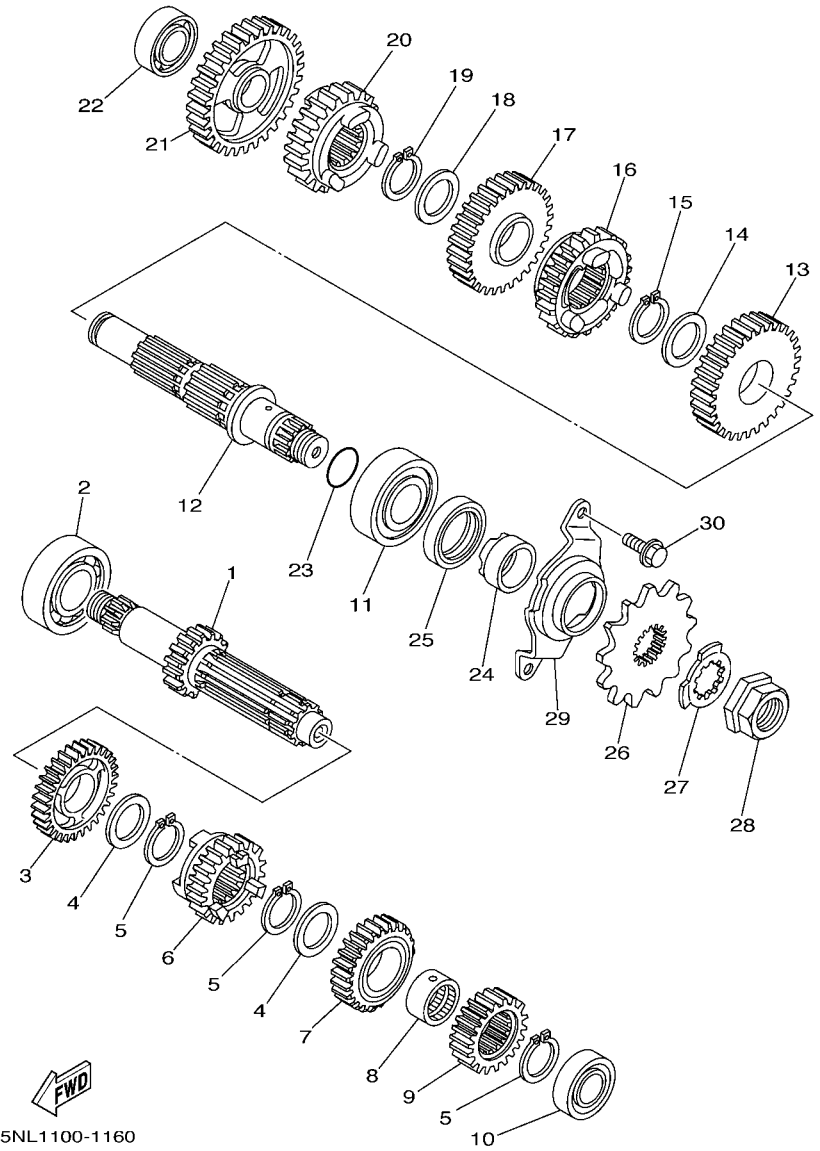
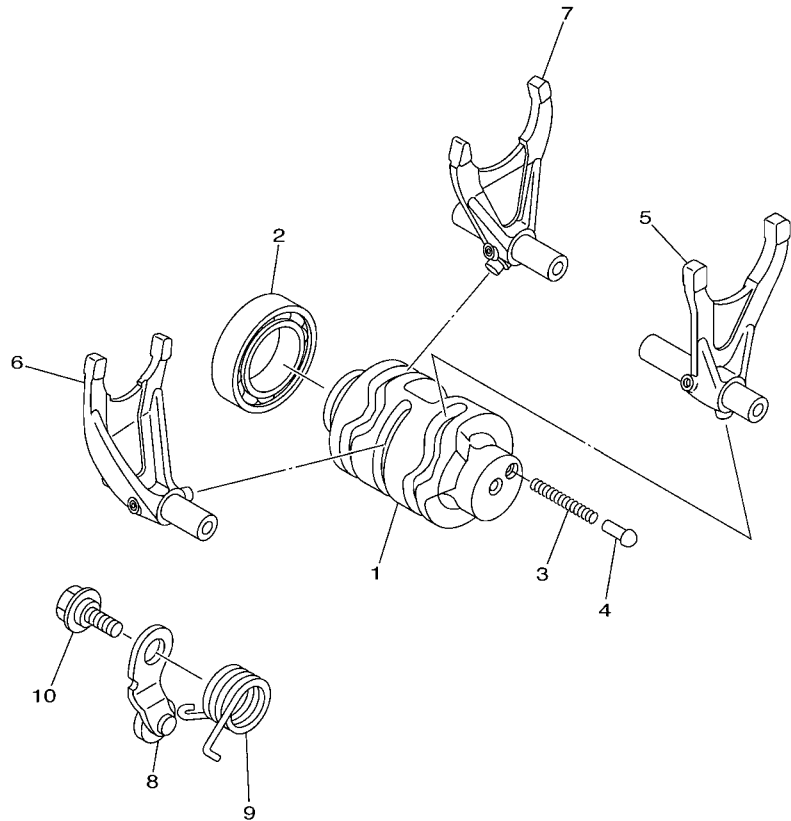

FIG. 16 TRANSMISSION

REF. NO.	PART NO.	DESCRIPTION	5XC1	5XC2	5XC3	5XC4	REMARKS
28	90179-18001	NUT	1	1	1	1	
29	5NL-17471-00	PLATE, COVER	1	1	1	1	
30	90105-06553	BOLT, FLANGE	2	2	2	2	

FIG. 17 SHIFT CAM & FORK



5NL1100-1170

REF. NO.	PART NO.	DESCRIPTION	5XC1	5XC2	5XC3	5XC4	REMARKS
1	5NL-18541-00	CAM, SHIFT	1	1	1	1	
2	93306-90501	BEARING	1	1	1	1	
3	90501-06022	SPRING, COMPRESSION	1	1	1	1	
4	4BA-18542-00	POINT, NEUTRAL	1	1	1	1	
5	5NL-18501-00	FORK, SHIFT 1	1	1	1	1	
6	5NL-18502-00	FORK, SHIFT 2	1	1	1	1	
7	5NL-18503-00	FORK, SHIFT 3	1	1	1	1	
8	3XK-18140-00	STOPPER LEVER ASSY	1	1	1	1	
9	90508-26561	SPRING, TORSION	1	1	1	1	
10	90109-063F8	BOLT	1	1	1	1	

FIG. 18 SHIFT SHAFT

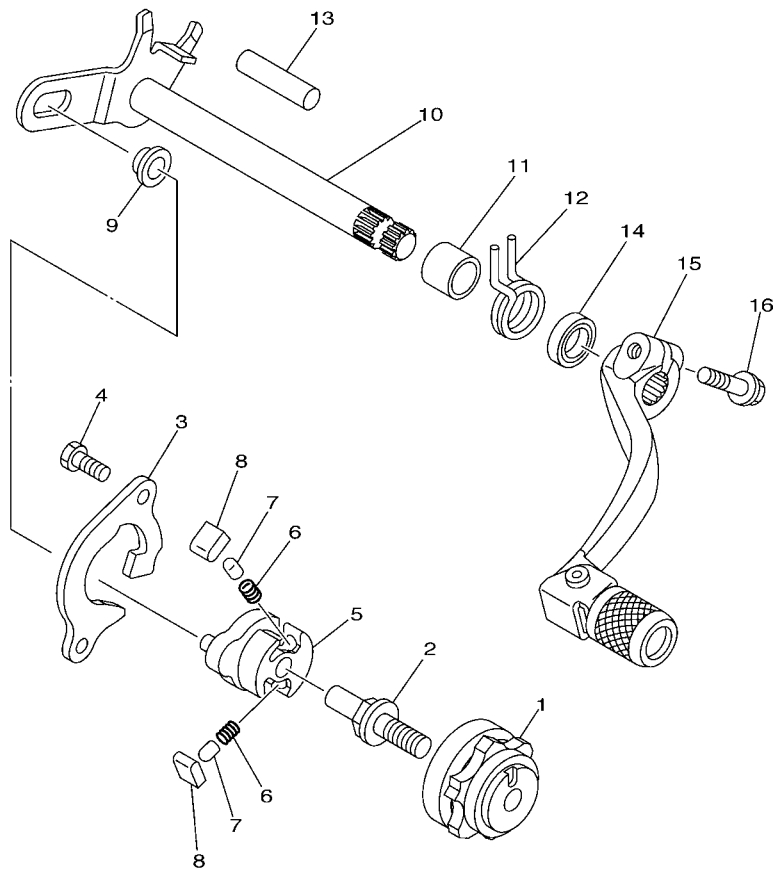

5NL1100-1180

REF. NO.	PART NO.	DESCRIPTION	5XC1	5XC2	5XC3	5XC4	REMARKS
1	4EW-18185-00	SEGMENT	1	1	1	1	
2	3XJ-18173-00	PIN, SHIFT	1	1	1	1	
3	5BE-18172-00	GUIDE, SHIFT	1	1	1	1	
4	90101-06664	BOLT	2	2	2	2	
5	5LP-18122-00	LEVER, SHIFT 2	1	1	1	1	
6	90501-052G5	SPRING, COMPRESSION	2	2	2	2	
7	3XJ-18184-00	PIN, PAWL	2	2	2	2	
8	3XJ-18182-00	PAWL, SHIFTER	2	2	2	2	
9	3XJ-18178-00	ROLLER, SHIFT LEVER	1	1	1	1	
10	5UL-18101-00	SHIFT SHAFT ASSY	1	1	1	1	
11	90387-124F4	COLLAR	1	1	1	1	
12	90508-291A8	SPRING, TORSION	1	1	1	1	
13	93608-33002	PIN, DOWEL	1	1	1	1	
14	93102-12224	OIL SEAL	1	1	1	1	
15	5UL-18110-00	SHIFT PEDAL ASSY	1	1	1	1	
16	95027-06020	BOLT, FLANGE	1	1	1	1	

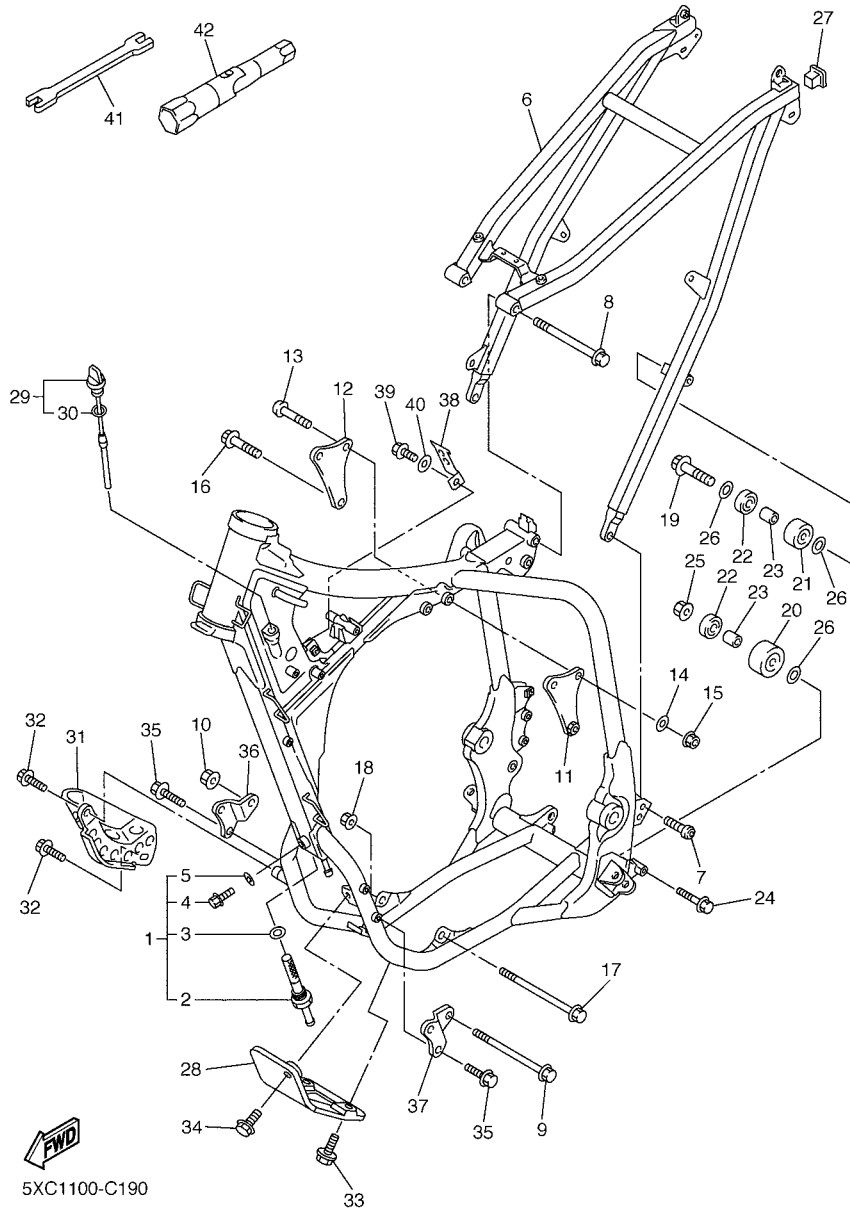

5XC1100-C190

FIG. 19 FRAME

REF. NO.	PART NO.	DESCRIPTION	5XC1	5XC2	5XC3	5XC4	REMARKS
1	5XC-21101-00	FRONT FRAME COMP.	1	1	1	1	
2	5TA-21756-00	.NET, FILTER	1	1	1	1	
3	90201-145M4	.WASHER, PLATE	1	1	1	1	
4	95827-08012	.BOLT, FLANGE	1	1	1	1	
5	90430-08119	.GASKET	1	1	1	1	
6	5XD-21190-00	REAR FRAME COMP.	1	1	1	1	
7	90110-08096	BOLT, HEXAGON SOCKET HEAD	2	2	2	2	
8	90105-08120	BOLT, FLANGE	1	1	1	1	
9	90105-10072	BOLT, FLANGE	1	1	1	1	
10	90179-10658	NUT	1	1	1	1	
11	5NL-21425-00	BRACKET, REAR UPPER 1	1	1	1	1	
12	5NL-21425-10	BRACKET, REAR UPPER 1	1	1	1	1	
13	92017-08055	BOLT, BUTTON HEAD	2	2	2	2	
14	90201-086P8	WASHER, PLATE	4	4	4	4	
15	90179-08674	NUT	2	2	2	2	
16	95817-10050	BOLT, FLANGE	1	1	1	1	
17	90105-10733	BOLT, FLANGE	1	1	1	1	
18	90179-10658	NUT	1	1	1	1	
19	95027-08040	BOLT, FLANGE	1	1	1	1	
20	3JD-22178-10	TENSIONER	1	1	1	1	
21	4EW-22178-00	TENSIONER	1	1	1	1	
22	93300-60804	BEARING	2	2	2	2	
23	90387-086N4	COLLAR	2	2	2	2	
24	95027-08065	BOLT, FLANGE	1	1	1	1	
25	95707-08500	NUT, FLANGE	1	1	1	1	
26	90201-086P8	WASHER, PLATE	3	3	3	3	
27	90338-18176	PLUG	1	1	1	1	

C14

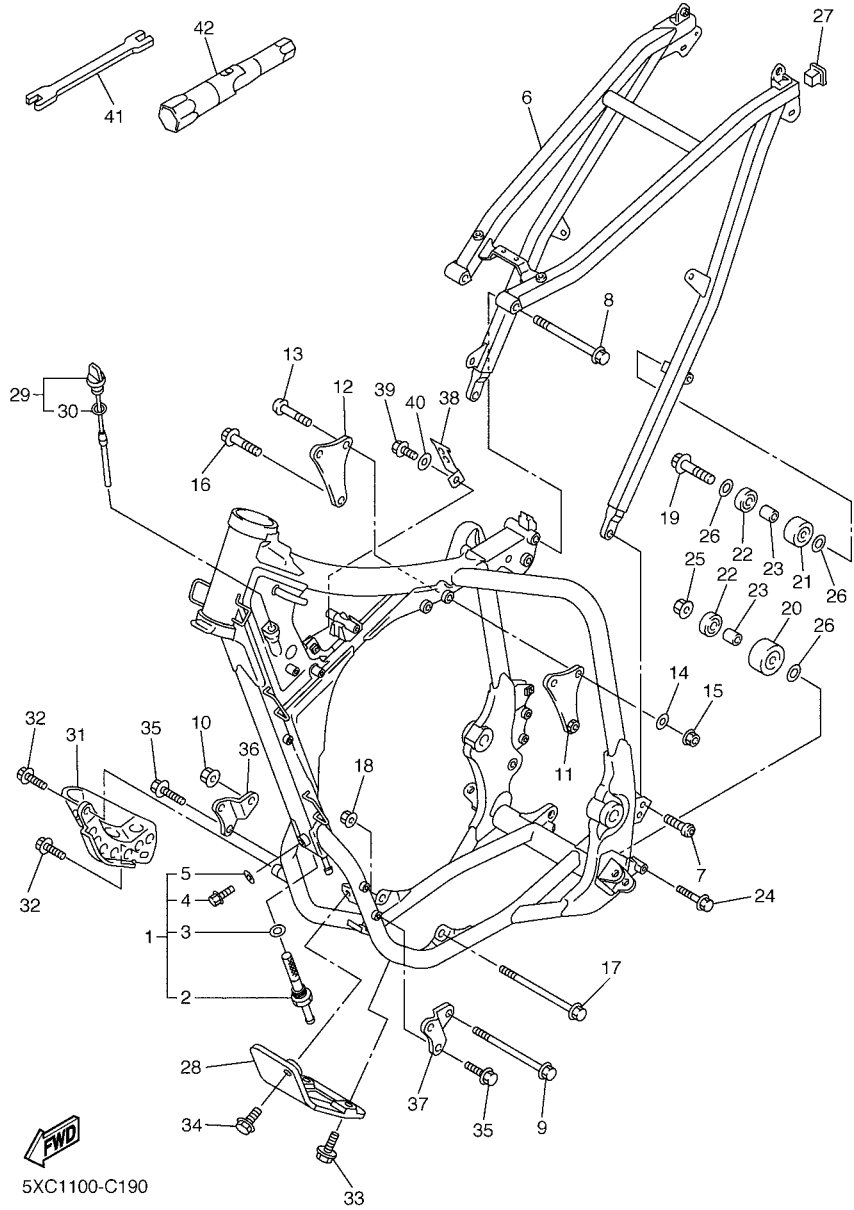

5XC1100-C190

FIG. 19 FRAME

REF. NO.	PART NO.	DESCRIPTION	5XC1	5XC2	5XC3	5XC4	REMARKS
28	5NL-21471-01	PROTECTOR, ENGINE	1	1	1	1	
29	5UL-15362-01	PLUG, OIL LEVEL	1	1	1	1	
30	93210-08001	.O-RING	1	1	1	1	
31	5NL-2147A-00	GUARD, ENGINE 1	1	1	1	1	
32	95027-08012	BOLT, FLANGE	2	2	2	2	
33	95027-06012	BOLT, FLANGE	2	2	2	2	
34	90119-06001	BOLT, WITH WASHER	1	1	1	1	
35	95817-08016	BOLT, FLANGE	4	4	4	4	
36	5UL-21417-00	BRACKET, FRONT LOWER 1	1	1	1	1	
37	5UL-21417-10	BRACKET, FRONT LOWER 1	1	1	1	1	
38	5TA-21274-01	BRACKET, C.D.I. UNIT	1	1	1	1	
39	97027-06012	BOLT	1	1	1	1	
40	92907-06600	WASHER, PLATE	1	1	1	1	
41	5ET-28166-00	WRENCH, HEXAGON	1	1	1	1	
42	5TA-2814F-00	BOX, SPARK PLUG	1	1	1	1	

FIG. 20 FENDER

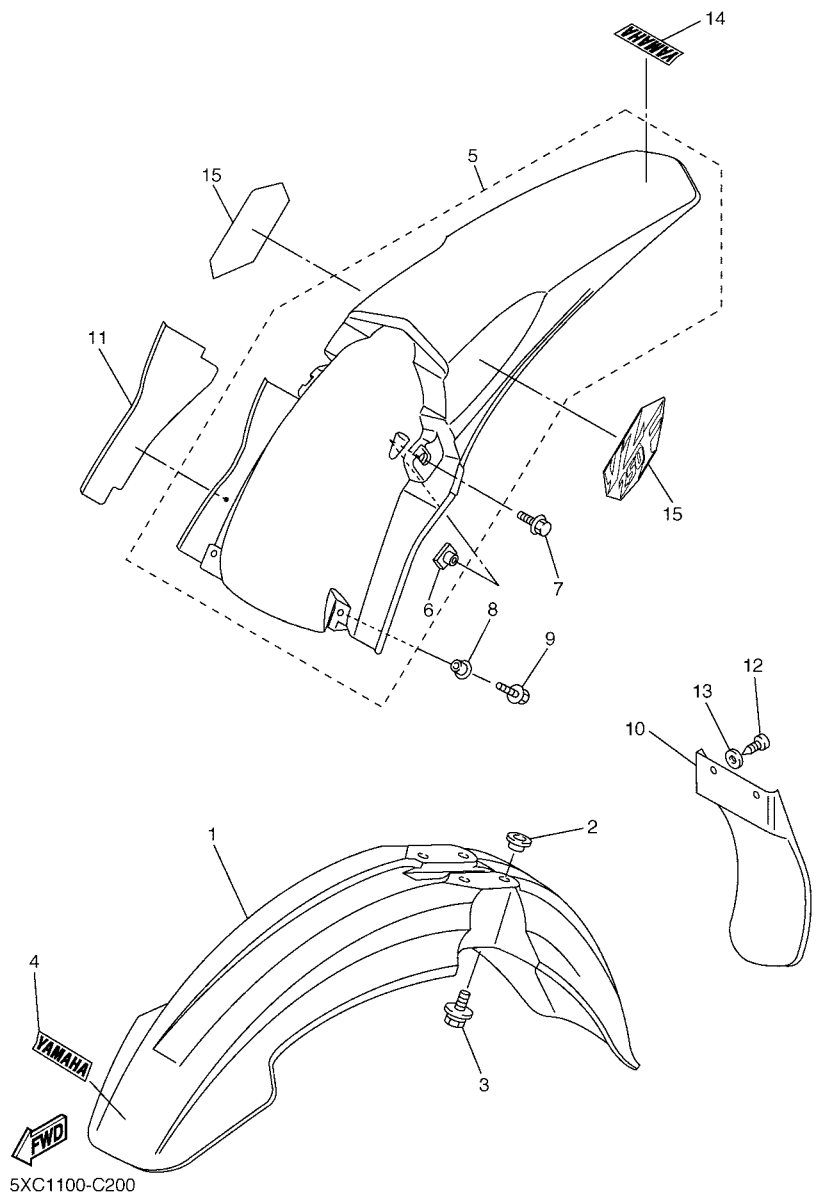

REF. NO.	PART NO.	DESCRIPTION	5XC1	5XC2	5XC3	5XC4	REMARKS
1	5HD-21511-00	FENDER, FRONT	1	1	1	1	
2	3JD-21748-00	COLLAR	4	4	4	4	
3	90119-06096	BOLT, WITH WASHER	4	4	4	4	
4	4ES-2153E-01	EMBLEM, YAMAHA	1	1	1	1	
5	5XD-21610-00	REAR FENDER COMP.	1	1	1	1	
6	5XD-21635-00	.NUT, REAR FENDER	2	2	2	2	
7	90119-06192	BOLT, WITH WASHER	2	2	2	2	
8	90387-06009	COLLAR	2	2	2	2	
9	90119-06225	BOLT, WITH WASHER	2	2	2	2	
10	5TA-21642-00	GUARD, FLAP	1	1	1	1	
11	5TA-2174T-00	INSULATOR, SIDE COVER 2	1	1	1	1	
12	97707-60016	SCREW, TAPPING	2	2	2	2	
13	90201-06557	WASHER, PLATE	2	2	2	2	
14	4ES-2153E-01	EMBLEM, YAMAHA	1	1	1	1	
15	5XC-2163G-00	EMBLEM 1	2	2	2	2	

FIG. 21 SIDE COVER

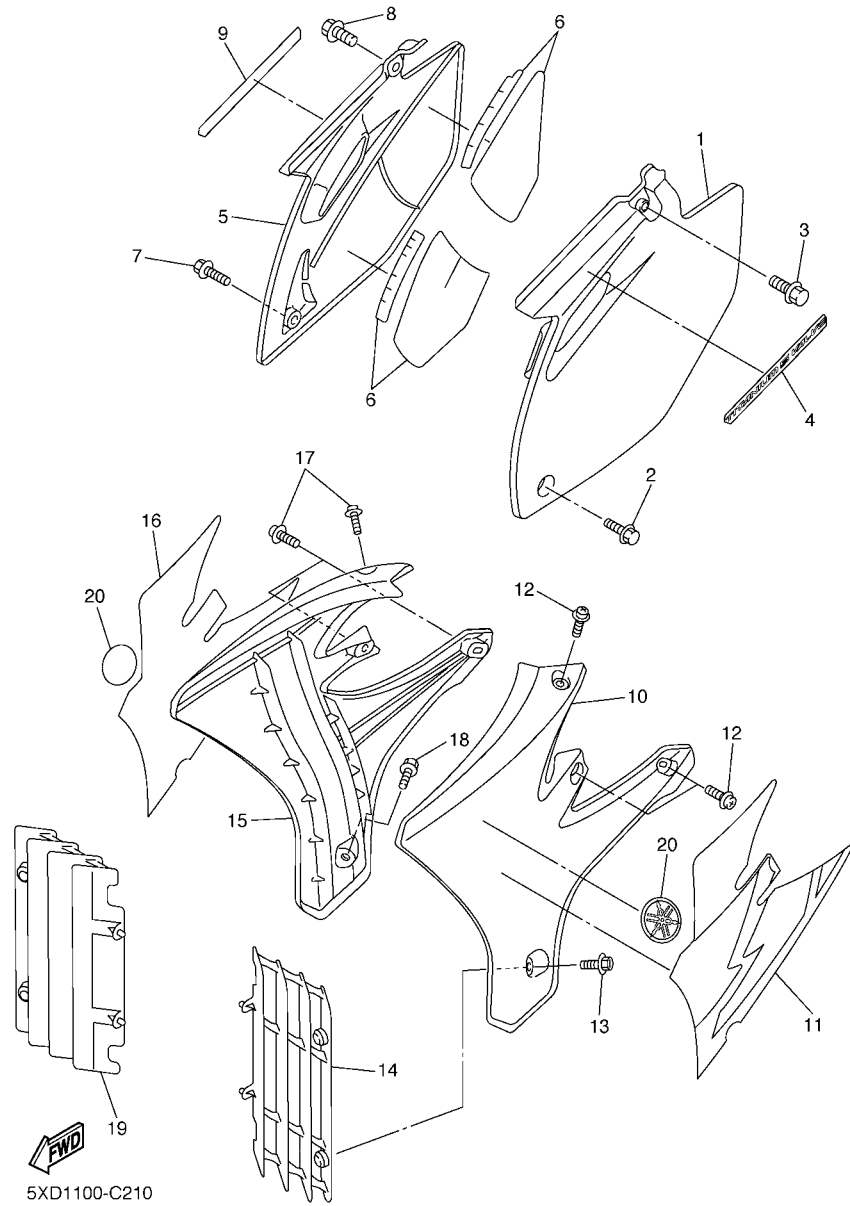

REF. NO.	PART NO.	DESCRIPTION	5XC1	5XC2	5XC3	5XC4	REMARKS
1	5TA-21711-00	COVER, SIDE 1	1	1	1	1	
2	95827-06016	BOLT, FLANGE	1	1	1	1	
3	90119-08238	BOLT, WITH WASHER	1	1	1	1	
4	5XD-21781-00	EMBLEM 1	1	1	1	1	
5	5TA-21721-00	COVER, SIDE 2	1	1	1	1	
6	5TA-2174A-00	INSULATOR, SIDE COVER	1	1	1	1	
7	95827-06016	BOLT, FLANGE	1	1	1	1	
8	90119-08238	BOLT, WITH WASHER	1	1	1	1	
9	5XD-21781-00	EMBLEM 1	1	1	1	1	
10	5TA-21730-00	SIDE COVER ASSY 3	1	1	1	1	
11	5XD-2173E-00	GRAPHIC 1	1	1	1	1	
12	90159-06182	SCREW, WITH WASHER	3	3	3	3	
13	90159-06078	SCREW, WITH WASHER	1	1	1	1	
14	5NL-2172A-11	PANEL 1	1	1	1	1	
15	5TA-21740-00	SIDE COVER ASSY 4	1	1	1	1	
16	5XD-2173F-00	GRAPHIC 2	1	1	1	1	
17	90159-06182	SCREW, WITH WASHER	3	3	3	3	
18	90159-06078	SCREW, WITH WASHER	1	1	1	1	
19	5NL-2172A-11	PANEL 1	1	1	1	1	
20	5MV-2175C-00	TUNING FORK MARK	2	2	2	2	

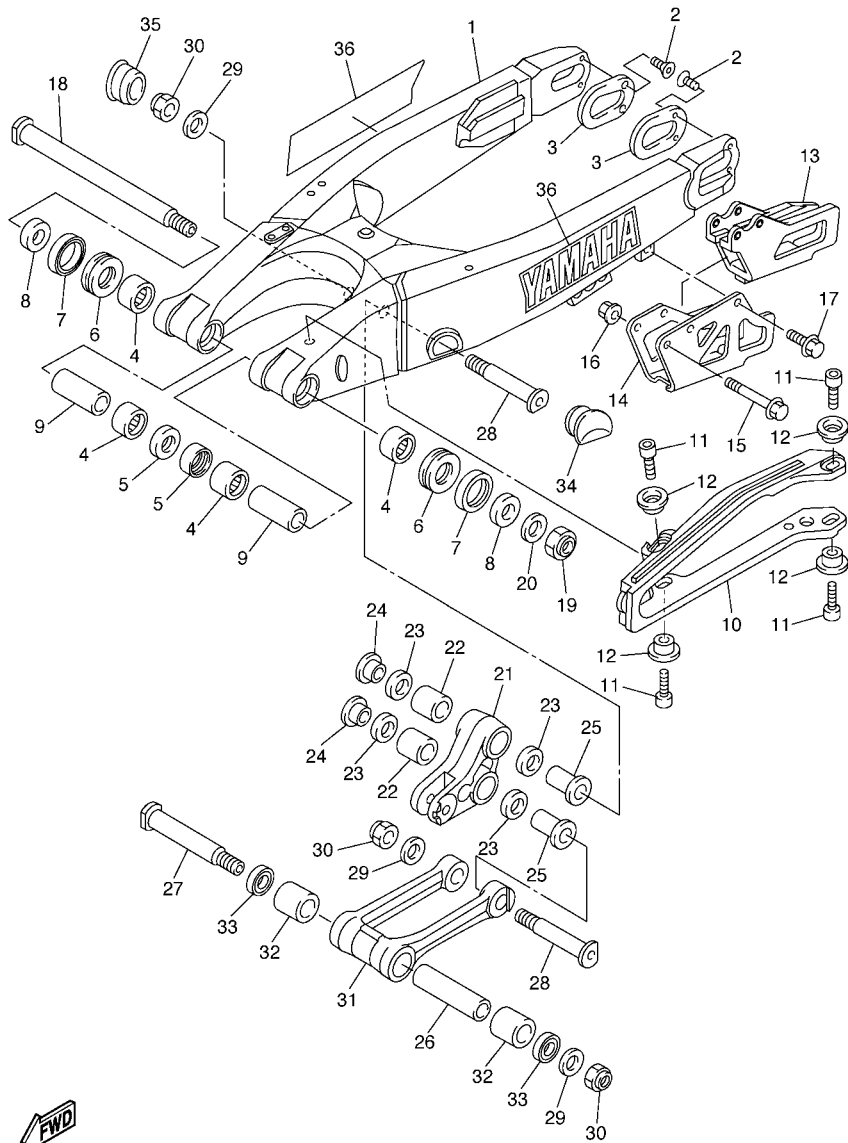

5XD1100-C220

FIG. 22 REAR ARM

REF. NO.	PART NO.	DESCRIPTION	5XC1	5XC2	5XC3	5XC4	REMARKS
1	5UN-22110-00	REAR ARM COMP.	1	1	1	1	
2	90151-04001	SCREW, COUNTERSUNK	4	4	4	4	
3	5UN-22355-00	PATCH	2	2	2	2	
4	93317-22262	BEARING	4	4	4	4	
5	93106-22019	OIL SEAL (DC 22-28-8)	2	2	2	2	
6	93342-22217	BEARING	2	2	2	2	
7	93109-28043	OIL SEAL	2	2	2	2	
8	90387-18005	COLLAR	2	2	2	2	
9	90387-18004	COLLAR	2	2	2	2	
10	5UN-22151-00	SEAL, GUARD	1	1	1	1	
11	91317-05008	BOLT	4	4	4	4	
12	5JG-22156-00	WASHER, PLATE	4	4	4	4	
13	5UN-22199-00	SUPPORT, CHAIN	1	1	1	1	
14	5UN-22128-00	COVER, THRUST 1	1	1	1	1	
15	95027-06050	BOLT, FLANGE	2	2	2	2	
16	90179-06568	NUT	2	2	2	2	
17	95027-06010	BOLT, FLANGE	1	1	1	1	
18	5NY-22141-01	SHAFT, PIVOT	1	1	1	1	
19	90185-16127	NUT, SELF-LOCKING	1	1	1	1	
20	90201-160F6	WASHER, PLATE	1	1	1	1	
21	5NY-2217A-00	ARM, RELAY	1	1	1	1	
22	93315-32056	BEARING	2	2	2	2	
23	93109-20076	OIL SEAL	4	4	4	4	
24	90387-16005	COLLAR	2	2	2	2	
25	90387-16007	COLLAR	2	2	2	2	
26	90387-167Y9	COLLAR	1	1	1	1	
27	5NY-22121-00	SHAFT 1	1	1	1	1	

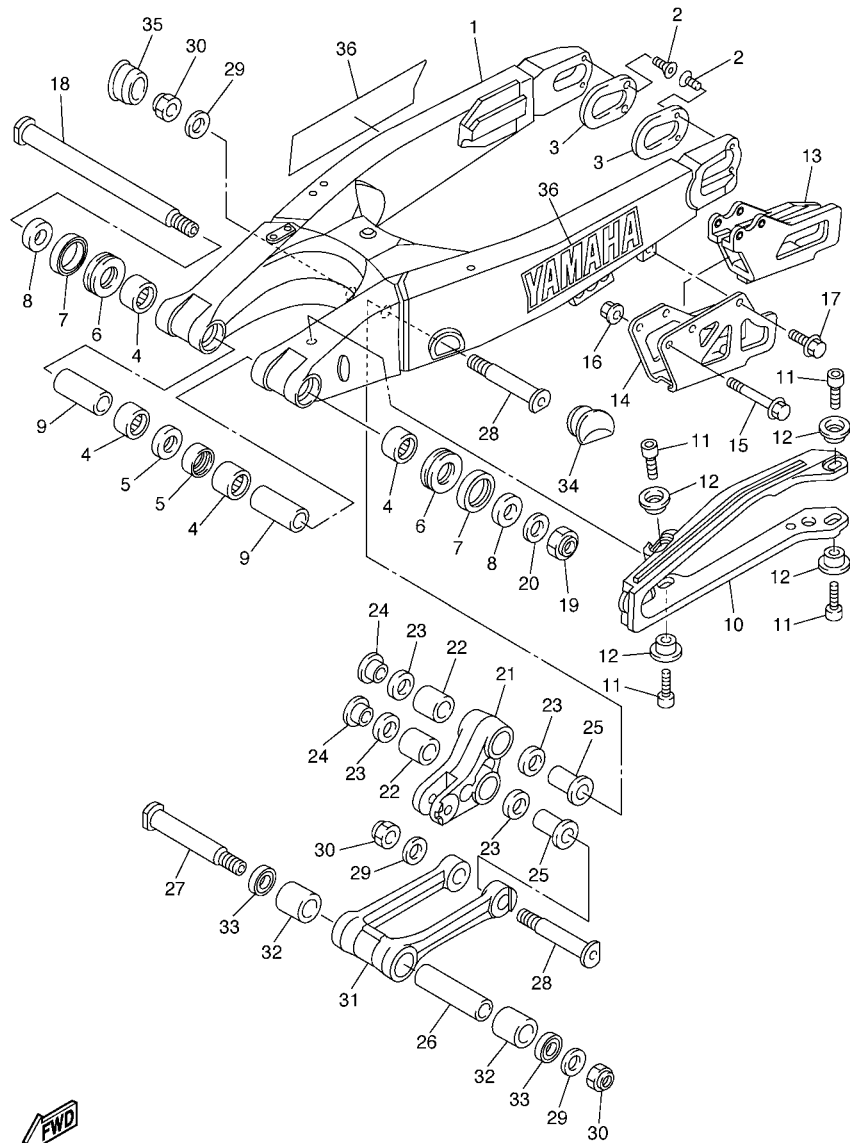

5XD1100-C220

FIG. 22 REAR ARM

REF. NO.	PART NO.	DESCRIPTION	5XC1	5XC2	5XC3	5XC4	REMARKS
28	5XE-22122-00	SHAFT 2	2	2	2	2	
29	90201-14740	WASHER, PLATE	3	3	3	3	
30	90185-14007	NUT, SELF-LOCKING	3	3	3	3	
31	5XE-2217F-00	ROD, CONNECTING 1	1	1	1	1	
32	93315-32053	BEARING	2	2	2	2	
33	93109-20076	OIL SEAL	2	2	2	2	
34	5XE-2135F-00	COVER	1	1	1	1	
35	5HD-2135F-00	COVER	1	1	1	1	
36	5UN-2153A-00	EMBLEM, YAMAHA	2	2	2	2	

FIG. 23 REAR SUSPENSION

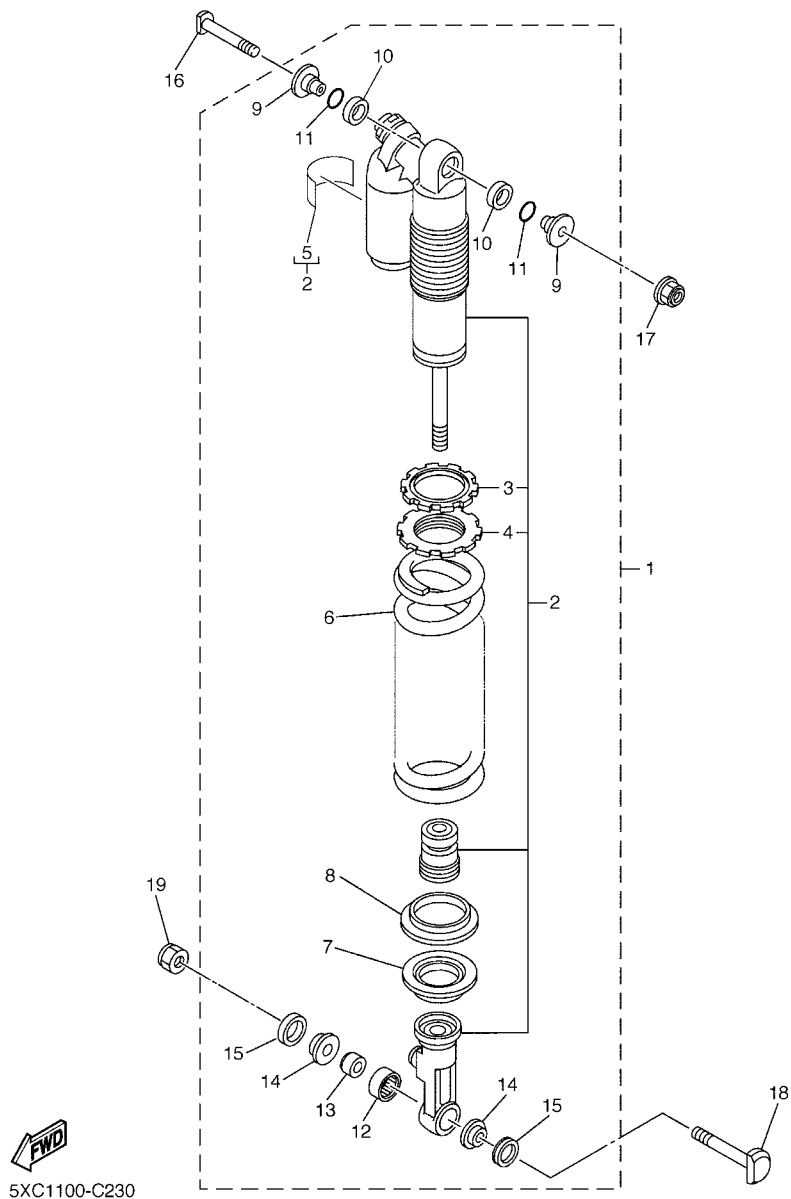

5XC1100-C230

REF. NO.	PART NO.	DESCRIPTION	5XC1	5XC2	5XC3	5XC4	REMARKS
1	5XC-22210-40	SHOCK ABSORBER ASSY, REAR				1	FOR ZAF
2	5XC-22201-40	.DAMPER SUB ASSY				1	FOR ZAF
3	3SP-22234-00	..GUIDE, SPRING 3	1	1	1	1	
4	3SP-22213-00	..SEAT, SPRING UPPER	1	1	1	1	
5	4AA-22259-80	..LABEL, WARNING	1				
	4AA-22259-40	..LABEL, WARNING		1		1	UR FOR OCE,ZAF
6	5UN-22212-20	.SPRING (K=46N/MM)	1		1	1	
7	5XE-22214-00	.GUIDE, SPRING 1	1	1	1	1	
8	5MV-22224-00	.GUIDE, SPRING 2	1	1	1	1	
9	5DH-22253-00	.COLLAR, DISTANCE	2	2	2	2	
10	3JE-22475-00	.SEAL, DUST	2	2	2	2	
11	4EW-22474-00	.SEAL, RING	2	2	2	2	
12	5UN-22176-00	.BEARING	1	1	1	1	
13	5MV-22184-00	.BUSH	1	1	1	1	
14	5MV-22253-00	.COLLAR, DISTANCE	2	2	2	2	
15	5NY-22475-00	.SEAL, DUST	2	2	2	2	

D6

FIG. 23 REAR SUSPENSION

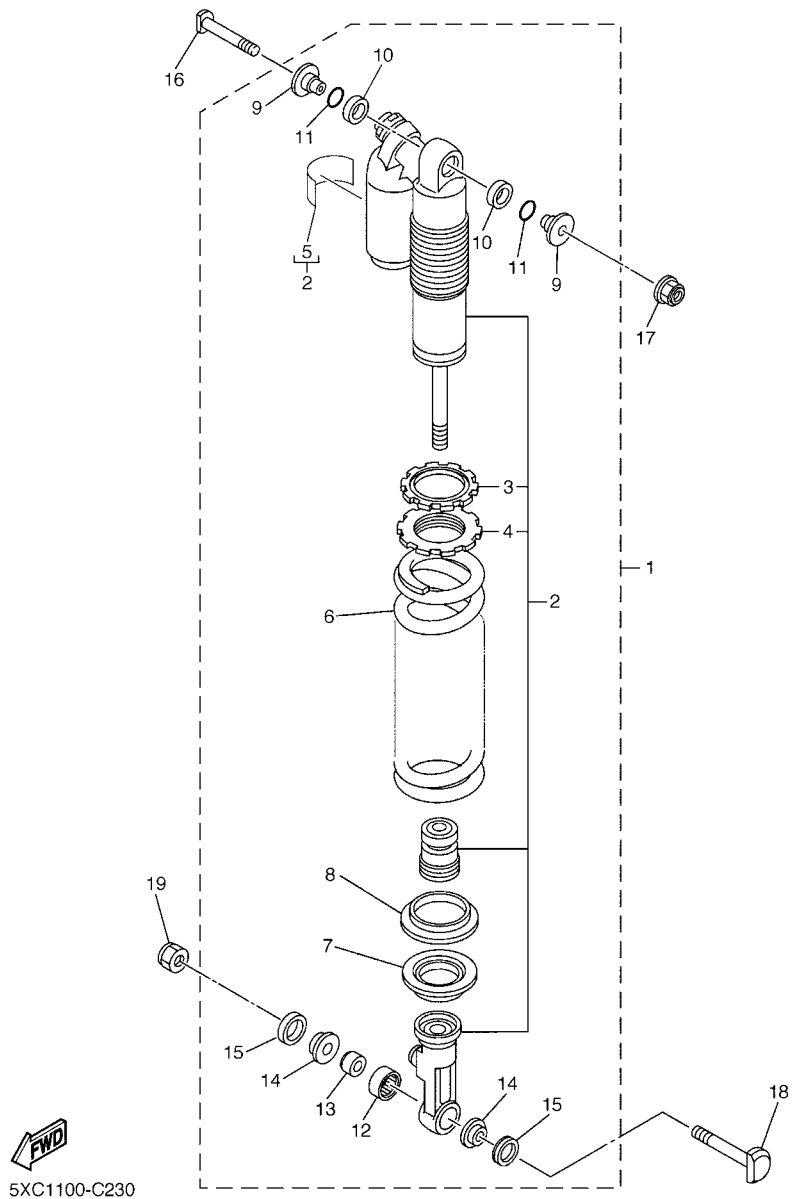

REF. NO.	PART NO.	DESCRIPTION	5XC1	5XC2	5XC3	5XC4	REMARKS
16	5XE-22242-00	BOLT 2	1	1	1	1	
17	95607-10200	NUT, SELF-LOCKING	1	1	1	1	
18	5NY-22241-00	BOLT 1	1	1	1	1	
19	90185-10060	NUT, SELF-LOCKING	1	1	1	1	

FIG. 24 STEERING

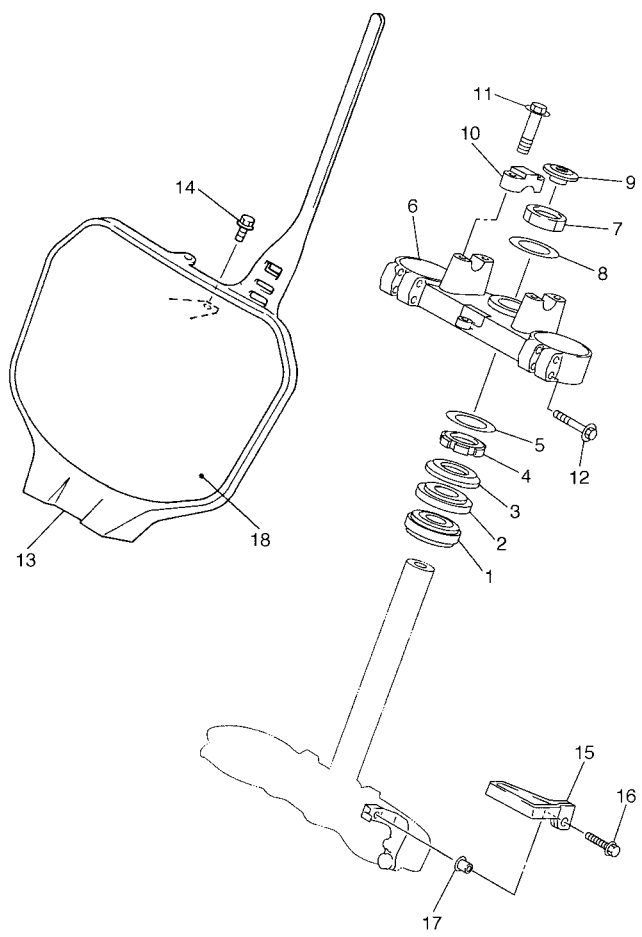

REF. NO.	PART NO.	DESCRIPTION	5XC1	5XC2	5XC3	5XC4	REMARKS
1	93332-00081	BEARING	1	1	1	1	
2	93332-00068	BEARING	1	1	1	1	
3	4EW-23416-00	COVER, BALL RACE 2	1	1	1	1	
4	90179-28003	NUT	1	1	1	1	
5	90201-286K9	WASHER, PLATE	1	1	1	1	
6	5XE-23435-00	CROWN, HANDLE	1	1	1	1	
7	5TA-23357-00	NUT	1	1	1	1	
8	90201-247L2	WASHER, PLATE	1	1	1	1	
9	5TJ-2319U-00	CAP	1	1	1	1	
10	5XE-23441-00	HOLDER, HANDLE UPPER	2	2	2	2	
11	95027-08035	BOLT, FLANGE	4	4	4	4	
12	95027-08040	BOLT, FLANGE	4	4	4	4	
13	5HD-23485-10	PLATE, NUMBER	1	1	1	1	
14	90119-06225	BOLT, WITH WASHER	1	1	1	1	
15	5XE-23389-00	GUIDE, CABLE	1	1	1	1	
16	95027-06020	BOLT, FLANGE	1	1	1	1	
17	5XE-23113-00	COLLAR	1	1	1	1	
18	5HD-2339E-00	GRAPHIC 1	1	1	1	1	



5XC1100-C240

FIG. 25 FRONT FORK

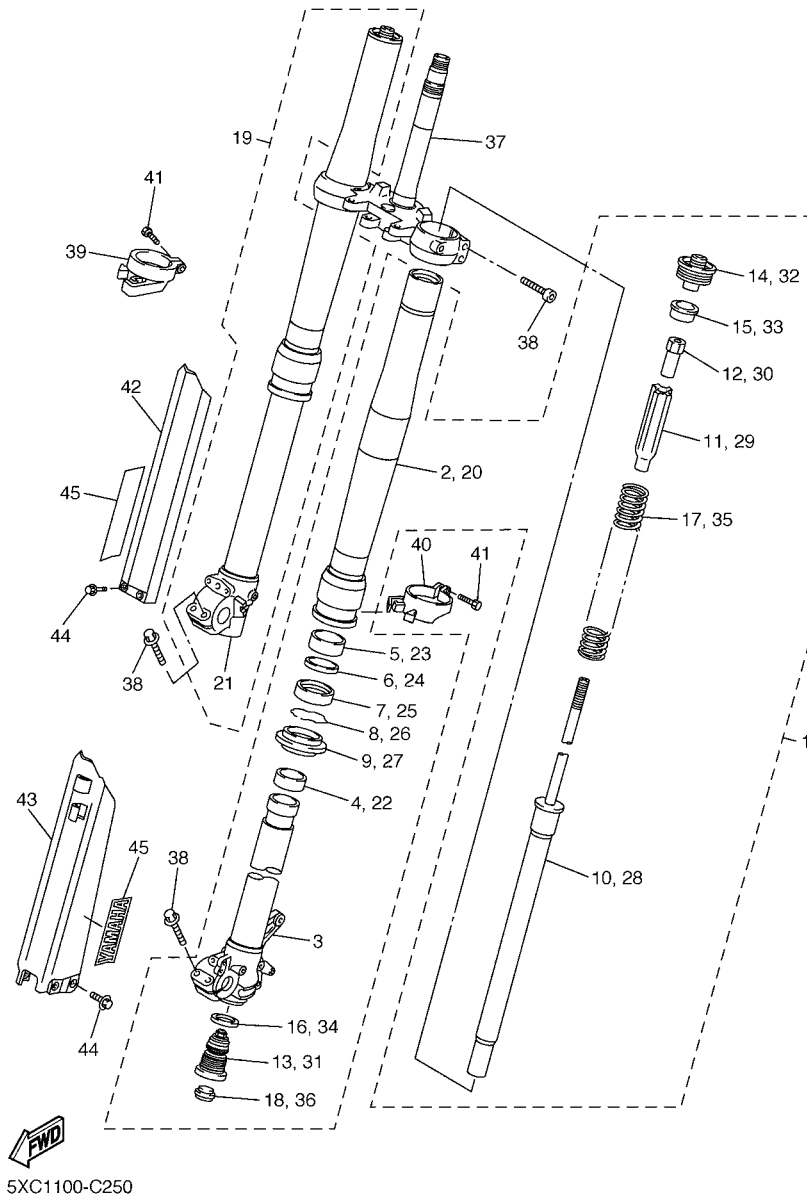

REF. NO.	PART NO.	DESCRIPTION	5XC1	5XC2	5XC3	5XC4	REMARKS
1	5XC-23102-00	FRONT FORK ASSY (L.H)	1			1	
2	5XD-23136-L0	.TUBE, OUTER (RIGHT)	1	1	1	1	
3	5XE-23120-L0	.INNER TUBE COMP.2	1	1	1	1	
4	5XE-23171-L0	.PISTON, FRONT FORK	1	1	1	1	
5	5XE-23125-L0	.METAL, SLIDE 1	1	1	1	1	
6	5XE-23146-L0	.WASHER, OIL SEAL	1	1	1	1	
7	5XE-23145-L0	.OIL SEAL	1	1	1	1	
8	5XE-23153-L0	.RING, SNAP	1	1	1	1	
9	5XE-23144-L0	.SEAL, DUST	1	1	1	1	
10	5XC-23170-L0	.CYLINDER COMP., FRONT FORK	1	1	1	1	
11	5XE-23142-L0	.SEAT, SPRING UPPER	1	1	1	1	
12	5XE-23393-L0	.NUT, SPECIAL	1	1	1	1	
13	5XC-2316A-L0	.VALVE COMP.	1			1	
14	5XE-23111-L0	.BOLT, CAP	1	1	1	1	
15	5XE-23117-L0	.GUIDE, SPRING	1	1	1	1	
16	4SS-23158-L0	.GASKET	1	1	1	1	
17	5XC-23141-L0	.SPRING, FRONT FORK(K=4.2N/MM)	1	1	1	1	
18	3JD-2312G-L0	.PLUG	1	1	1	1	
19	5XC-23103-00	FRONT FORK ASSY (R.H)	1			1	
20	5XD-23136-L0	.TUBE, OUTER (RIGHT)	1	1	1	1	
21	5XE-23110-L0	.INNER TUBE COMP.1	1	1	1	1	
22	5XE-23171-L0	.PISTON, FRONT FORK	1	1	1	1	
23	5XE-23125-L0	.METAL, SLIDE 1	1	1	1	1	
24	5XE-23146-L0	.WASHER, OIL SEAL	1	1	1	1	

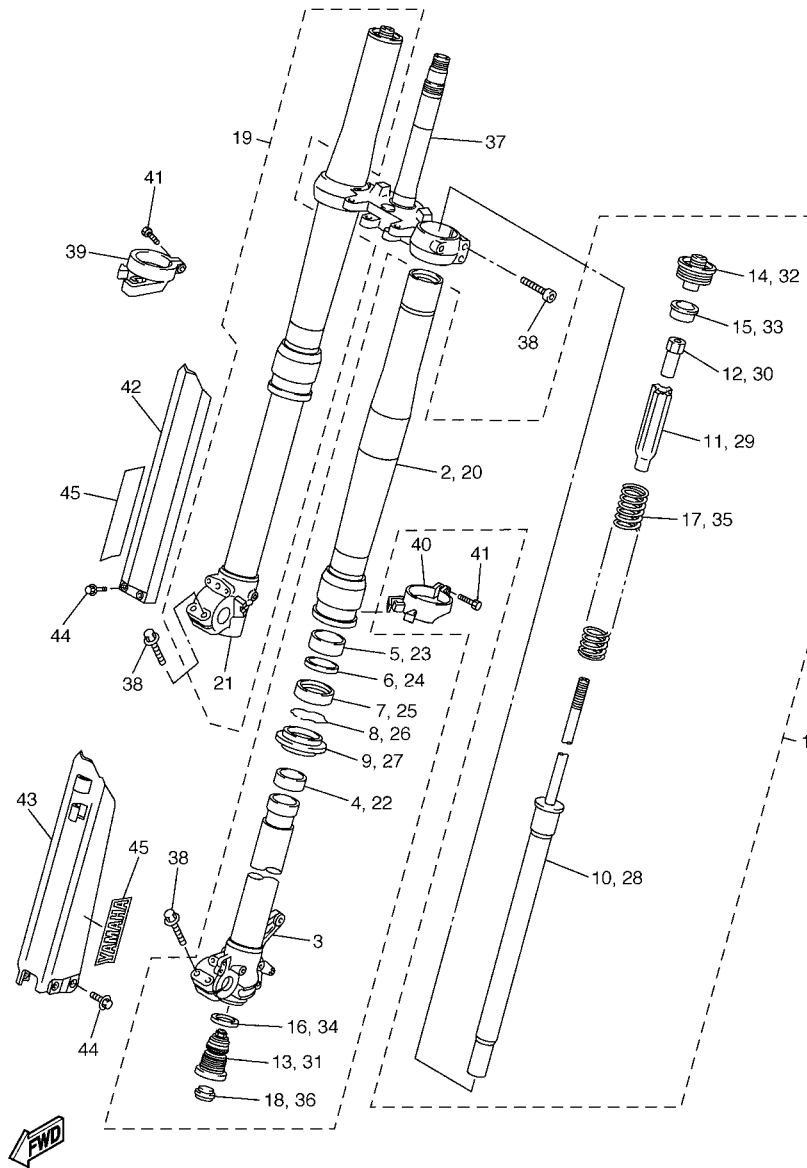

5XC1100-C250

FIG. 25 FRONT FORK

REF. NO.	PART NO.	DESCRIPTION	5XC1	5XC2	5XC3	5XC4	REMARKS
25	5XE-23145-L0	.OIL SEAL	1	1	1	1	
26	5XE-23153-L0	.RING, SNAP	1	1	1	1	
27	5XE-23144-L0	.SEAL, DUST	1	1	1	1	
28	5XC-23170-L0	.CYLINDER COMP., FRONT FORK	1	1	1	1	
29	5XE-23142-L0	.SEAT, SPRING UPPER	1	1	1	1	
30	5XE-23393-L0	.NUT, SPECIAL	1	1	1	1	
31	5XC-2316A-L0	.VALVE COMP.	1			1	
32	5XE-23111-L0	.BOLT, CAP	1	1	1	1	
33	5XE-23117-L0	.GUIDE, SPRING	1	1	1	1	
34	4SS-23158-L0	.GASKET	1	1	1	1	
35	5XC-23141-L0	.SPRING, FRONT FORK(K=4.2N/MM)	1	1	1	1	
36	3JD-2312G-L0	.PLUG	1	1	1	1	
37	5XC-23340-L0	UNDER BRACKET COMP.	1	1	1	1	
38	5NY-23346-L0	BOLT 1	8	8	8	8	
39	5XE-2314G-L0	PROTECTOR GUIDE COMP., 2	1	1	1	1	
40	5XE-2314F-L0	PROTECTOR GUIDE COMP., 1	1	1	1	1	
41	4SS-23346-L0	BOLT 1	2	2	2	2	
42	5TA-2314J-00	PROTECTOR COMP., 2	1	1	1	1	
43	5TA-2314H-00	PROTECTOR COMP., 1	1	1	1	1	
44	3SP-23356-L0	BOLT 2	6	6	6	6	
45	4XL-2153A-10	EMBLEM, YAMAHA	2	2	2	2	

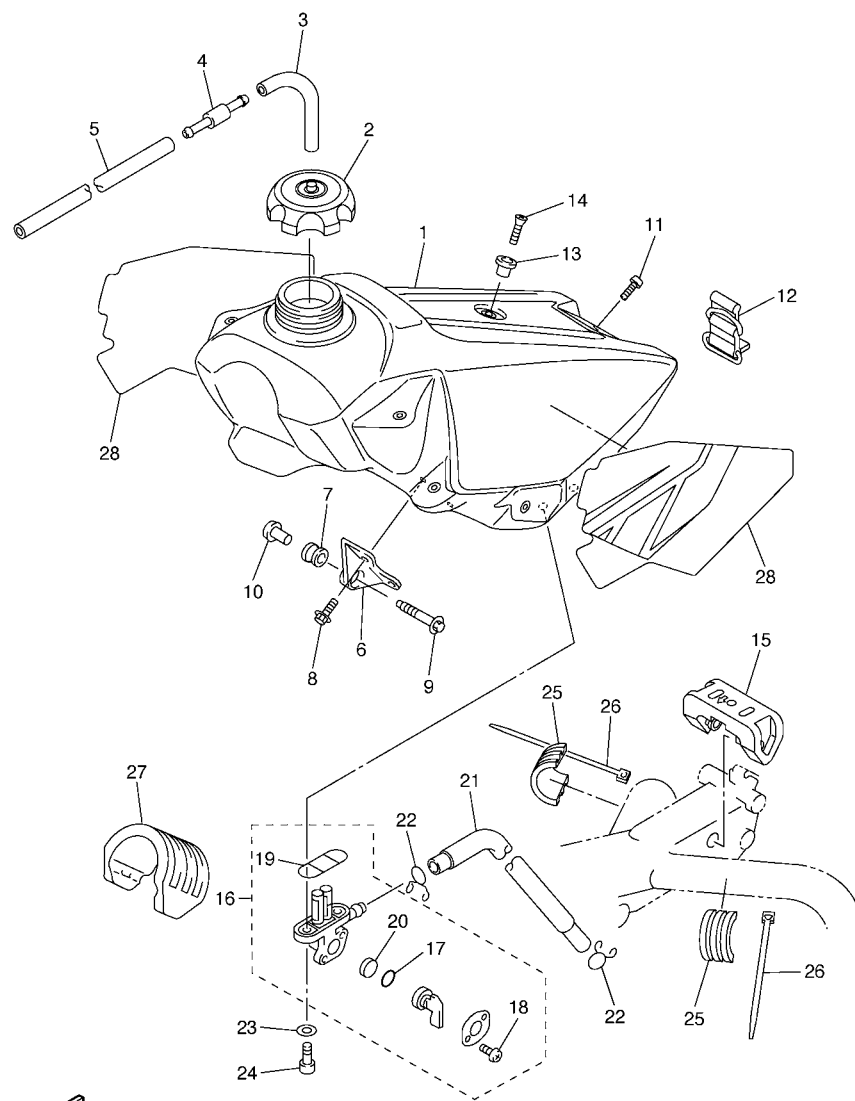

5XD1100-C260

FIG. 26 FUEL TANK

REF. NO.	PART NO.	DESCRIPTION	5XC1	5XC2	5XC3	5XC4	REMARKS
1	5XD-24110-00	FUEL TANK COMP.	1	1	1	1	
2	5NY-24610-00	CAP ASSY	1	1	1	1	
3	90445-09220	HOSE (L30)	1	1	1	1	
4	3XJ-24380-00	PIPE JOINT ASSY	1	1	1	1	
5	90445-09095	HOSE (L215)	1	1	1	1	
6	5XE-24144-00	HOLDER, DAMPER	2	2	2	2	
7	90480-18549	GROMMET	2	2	2	2	
8	95027-06016	BOLT, FLANGE	4	4	4	4	
9	5XE-24176-00	BOLT 1	2	2	2	2	
10	5NY-24186-00	WASHER, SPECIAL	2	2	2	2	
11	98907-06025	SCREW, BIND	1	1	1	1	
12	5SF-24173-00	BAND, TANK FITTING 1	1	1	1	1	
13	4EW-2412F-00	BRACKET, SEAT	1	1	1	1	
14	98707-06025	SCREW, FLAT HEAD	1	1	1	1	
15	4SS-24181-00	DAMPER, LOCATING 1	1	1	1	1	
16	4DP-24500-00	FUEL COCK ASSY 1	1	1	1	1	
17	3AJ-24534-00	.SEAL, COCK	1	1	1	1	
18	97801-03008	.SCREW, PAN HEAD	2	2	2	2	
19	4X8-24512-00	.O-RING	1	1	1	1	
20	3AJ-24523-00	.VALVE PACKING	1	1	1	1	
21	90445-11185	HOSE	1	1	1	1	
22	90467-10008	CLIP	2	2	2	2	
23	90202-05193	WASHER, PLATE	2	2	2	2	
24	90149-06011	SCREW	2	2	2	2	
25	5NY-24183-00	DAMPER, LOCATING 3	2	2	2	2	
26	90465-13152	CLAMP	2	2	2	2	
27	5BE-24182-00	DAMPER, LOCATING 2	1	1	1	1	

FIG. 26 FUEL TANK

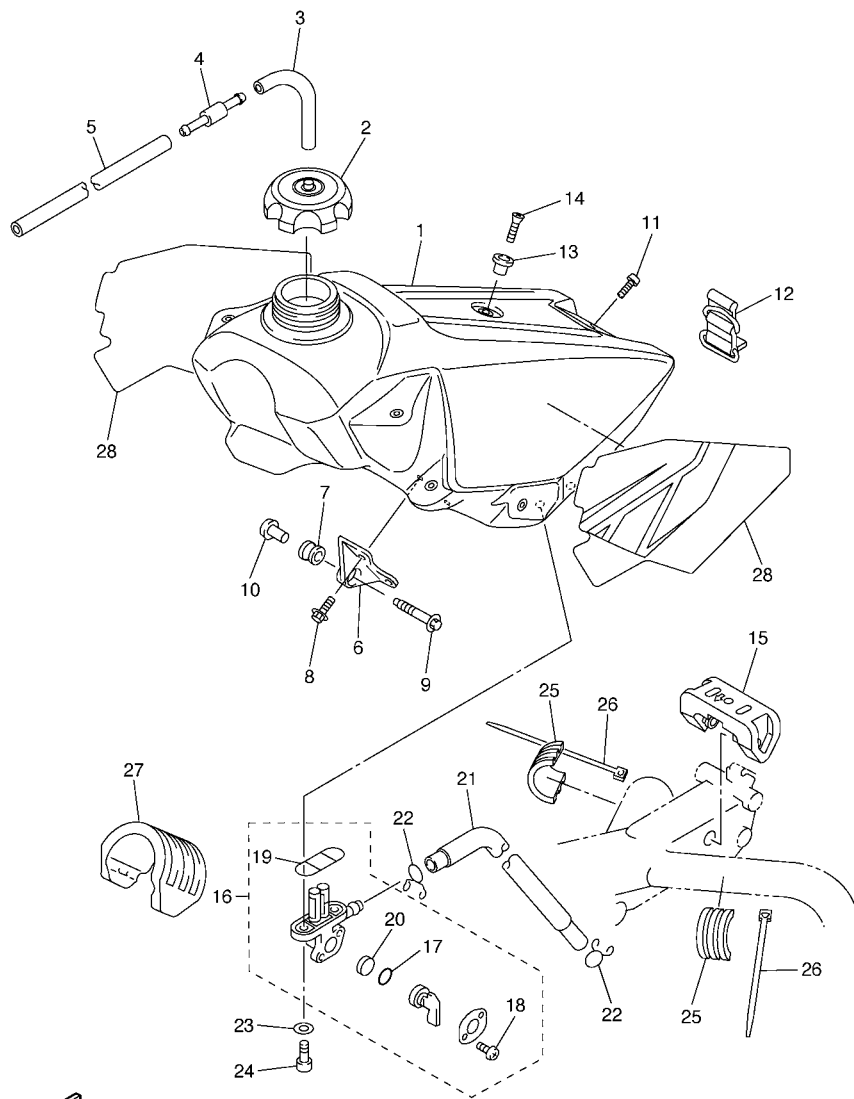

5XD1100-C260

REF. NO.	PART NO.	DESCRIPTION	5XC1	5XC2	5XC3	5XC4	REMARKS
28	5XD-24240-00	GRAPHIC SET	1	1	1	1	

FIG. 27 SEAT

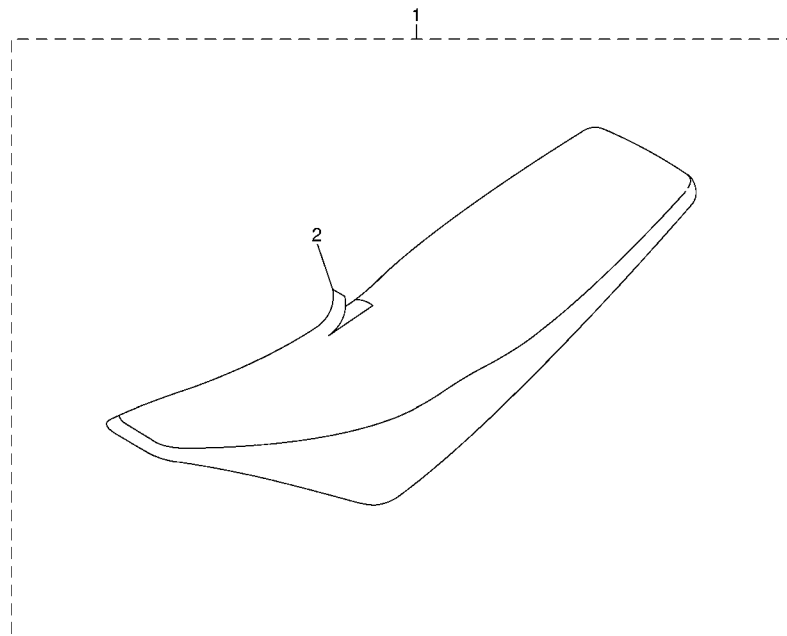

REF. NO.	PART NO.	DESCRIPTION	5XC1	5XC2	5XC3	5XC4	REMARKS
1	5XD-24710-00	SINGLE SEAT ASSY	1	1	1	1	
2	5XD-2470F-00	.SEAT COVER COMP.	1	1	1	1	



5XD1100-C270

FIG. 28 FRONT WHEEL

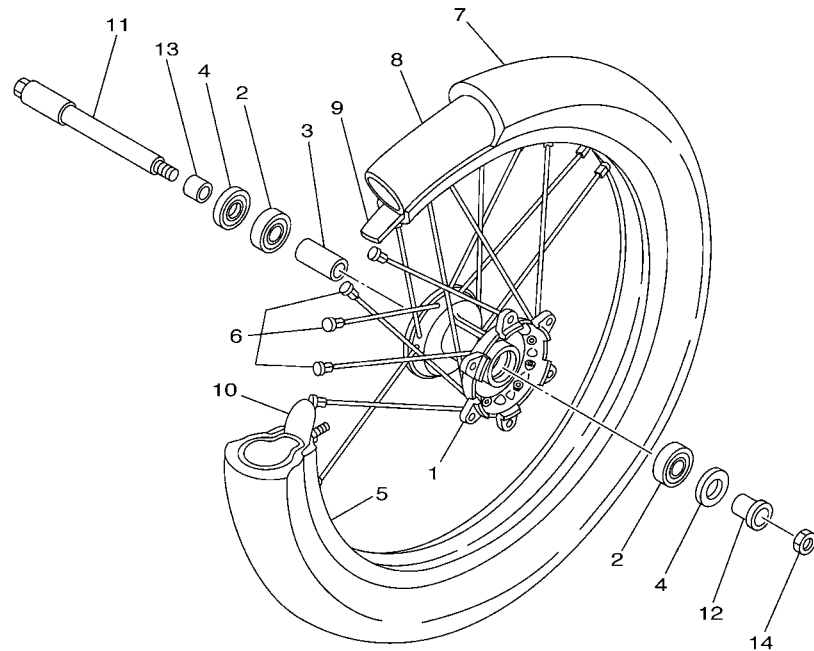

REF. NO.	PART NO.	DESCRIPTION	5XC1	5XC2	5XC3	5XC4	REMARKS
1	5NY-25111-00	HUB, FRONT	1	1	1	1	
2	93306-90403	BEARING	2	2	2	2	
3	5NY-25117-00	SPACER, BEARING	1	1	1	1	
4	93102-26468	OIL SEAL	2	2	2	2	
5	94416-21005	RIM (1.60-21)	1	1	1	1	
6	5NY-25104-00	SPOKE SET, FRONT	1	1	1	1	
7	L.M.	TYRE (80/100-21 51M D739FA)	1			1	
8	L.M.	TUBE (80/100-21 M/C TR4)	1	1		1	
9	94309-21161	BAND, RIM (1.60-21)	1	1		1	
10	5SF-25394-00	SPACER, BEAD	1	1	1	1	
11	5BE-25181-00	AXLE, WHEEL	1	1	1	1	
12	5NY-25183-00	COLLAR, WHEEL	1	1	1	1	
13	5NY-25186-00	COLLAR, WHEEL	1	1	1	1	
14	90179-16672	NUT	1	1	1	1	



5NL1100-1280

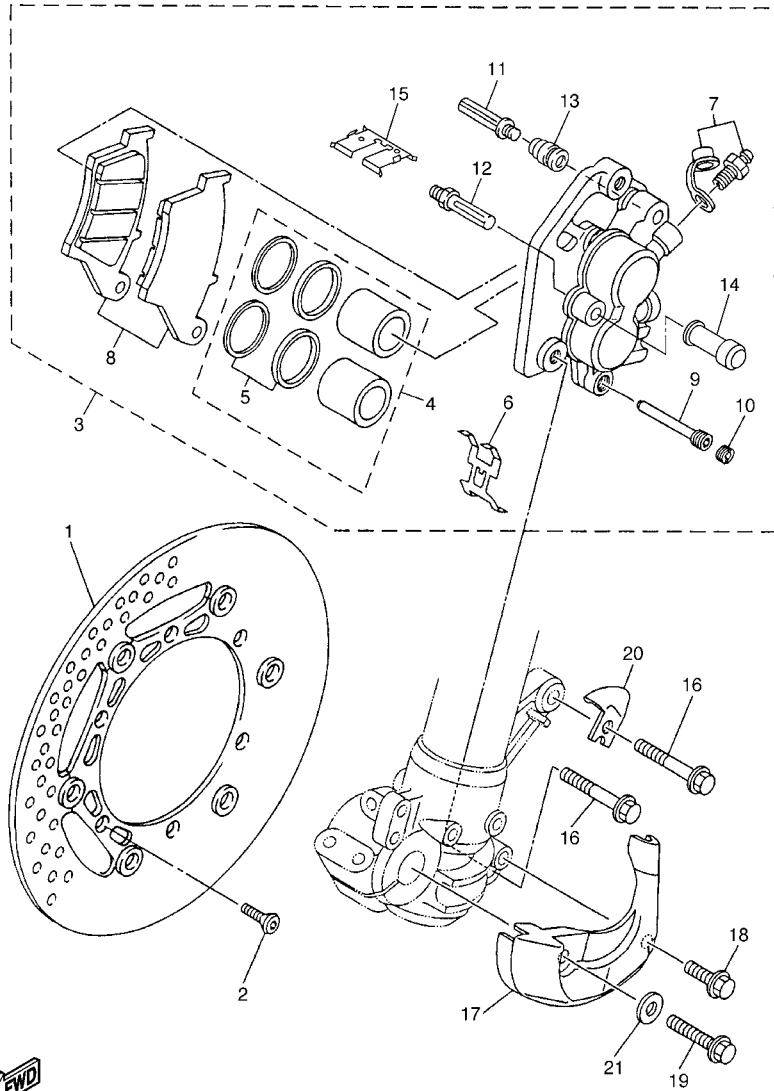

5XD1100-C290

FIG. 29 FRONT BRAKE CALIPER

REF. NO.	PART NO.	DESCRIPTION	5XC1	5XC2	5XC3	5XC4	REMARKS
1	5MV-2581T-00	DISC BRAKE ASSY	1	1	1	1	
2	90149-06327	SCREW	6	6	6	6	
3	5UN-2580T-00	CALIPER ASSY (LEFT)	1	1	1	1	
4	5UN-W0057-00	.PISTON ASSY, CALIPER	1	1	1	1	
5	3JD-W0047-00	..CALIPER SEAL KIT	1	1	1	1	
6	5DH-25919-00	..SUPPORT, PAD	1	1	1	1	
7	1UY-W0048-50	.BLEED SCREW KIT	1	1	1	1	
8	5MV-W0045-01	.BRAKE PAD KIT	1	1	1	1	
9	5DH-25933-00	.PIN, PAD	1	1	1	1	
10	5DH-25916-00	.PLUG	1	1	1	1	
11	3SP-25926-51	.BOLT	1	1	1	1	
12	3SP-25914-51	.PIN, SLIDE	1	1	1	1	
13	3JD-25917-00	.BOOT, CALIPER	1	1	1	1	
14	1UY-25937-51	.BOOT 2	1	1	1	1	
15	5DH-25849-00	.RETAINER, CALIPER	1	1	1	1	
16	90105-08659	BOLT, FLANGE	2	2	2	2	
17	5DH-2314E-00	COVER, HOSE	1	1	1	1	
18	95827-06012	BOLT, FLANGE	1	1	1	1	
19	95027-08020	BOLT, FLANGE	1	1	1	1	
20	5DH-25875-00	HOLDER, BRAKE HOSE 1	1	1	1	1	
21	92907-08200	WASHER	1	1	1	1	

FIG. 30 REAR WHEEL

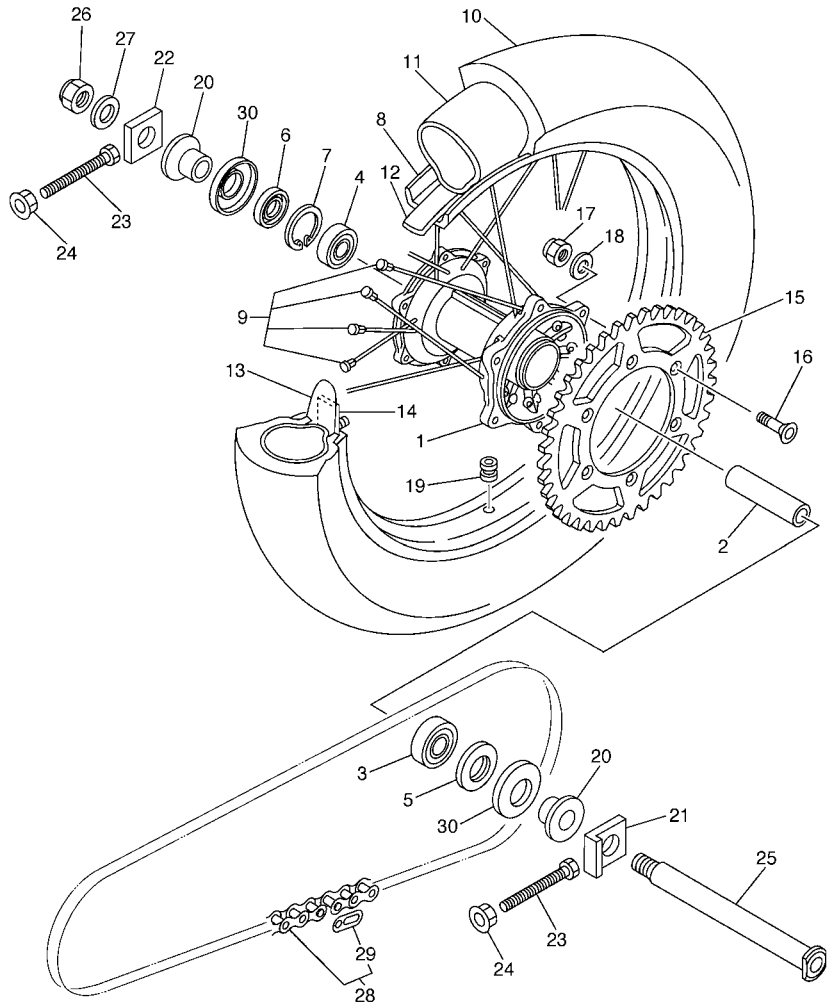

5SG1100-2300

REF. NO.	PART NO.	DESCRIPTION	5XC1	5XC2	5XC3	5XC4	REMARKS
1	5ET-25311-00	HUB, REAR	1	1	1	1	
2	5ET-25317-00	SPACER, BEARING	1	1	1	1	
3	93306-27205	BEARING	1	1	1	1	
4	93306-07202	BEARING	1	1	1	1	
5	93106-30044	OIL SEAL	1	1	1	1	
6	93106-30045	OIL SEAL	1	1	1	1	
7	99009-45500	CIRCLIP	1	1	1	1	
8	94418-19003	RIM (1.85-19)	1	1	1	1	
9	5HD-25304-00	SPOKE SET, REAR	1	1	1	1	
10	L.M.	TYRE (100/90-19 57M D739)	1			1	
11	L.M.	TUBE (100/90-19 M/C TR4 BTL)	1	1		1	
12	94321-19135	BAND, RIM (1.85-19)	1	1		1	
13	4XM-25394-00	SPACER, BEAD	1	1	1	1	
14	4XM-25364-00	DAMPER	1	1	1	1	
15	5NY-25448-00	SPROCKET, DRIVEN (48T)	1		1	1	STD
	5ET-25447-00	SPROCKET, DRIVEN (47T)	1	1	1	1	AP
	5NY-25449-00	SPROCKET, DRIVEN (49T)	1		1	1	AP
	5NY-25450-00	SPROCKET, DRIVEN (50T)	1	1	1	1	AP

FIG. 30 REAR WHEEL

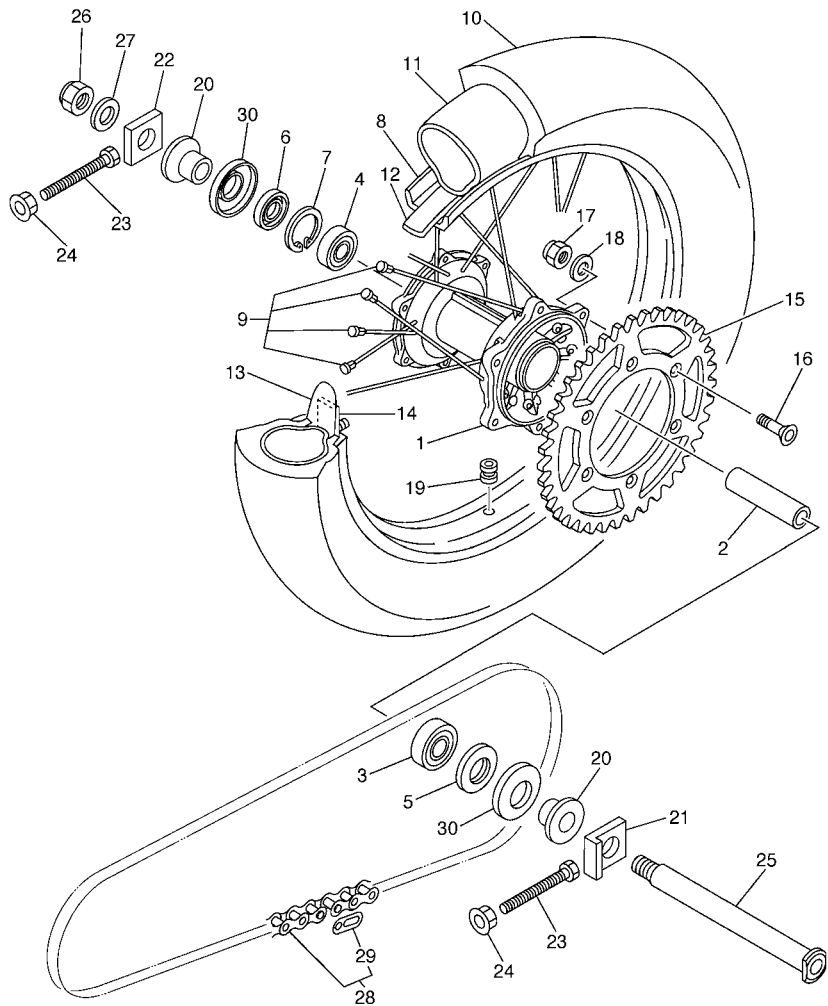

5SG1100-2300

REF. NO.	PART NO.	DESCRIPTION	5XC1	5XC2	5XC3	5XC4	REMARKS
15	5NY-25451-00	SPROCKET, DRIVEN (51T)	1	1	1	1	AP
	5NY-25452-00	SPROCKET, DRIVEN (52T)	1	1	1	1	AP
16	90109-081G1	BOLT	6	6	6	6	
17	90185-08169	NUT, SELF-LOCKING	6	6	6	6	
18	90201-08326	WASHER, PLATE	6	6	6	6	
19	90480-08608	GROMMET	1	1	1	1	
20	5UN-25383-00	COLLAR, WHEEL	2	2	2	2	
21	5NY-25388-00	PULLER, CHAIN 1	1	1	1	1	
22	5NY-25389-00	PULLER, CHAIN 2	1	1	1	1	
23	90101-08777	BOLT	2	2	2	2	
24	95707-08500	NUT, FLANGE	2	2	2	2	
25	5ET-25381-00	AXLE, WHEEL	1	1	1	1	
26	90185-20168	NUT, SELF-LOCKING	1	1	1	1	
27	90201-203U1	WASHER, PLATE	1	1	1	1	
28	9Y581-92111	CHAIN (DID 520D 112L)	1	1	1	1	
29	94681-68001	.JOINT,CHAIN (DID 520DM-RJ)	1	1	1	1	
30	5ET-25367-00	COVER, HUB DUST	2	2	2	2	

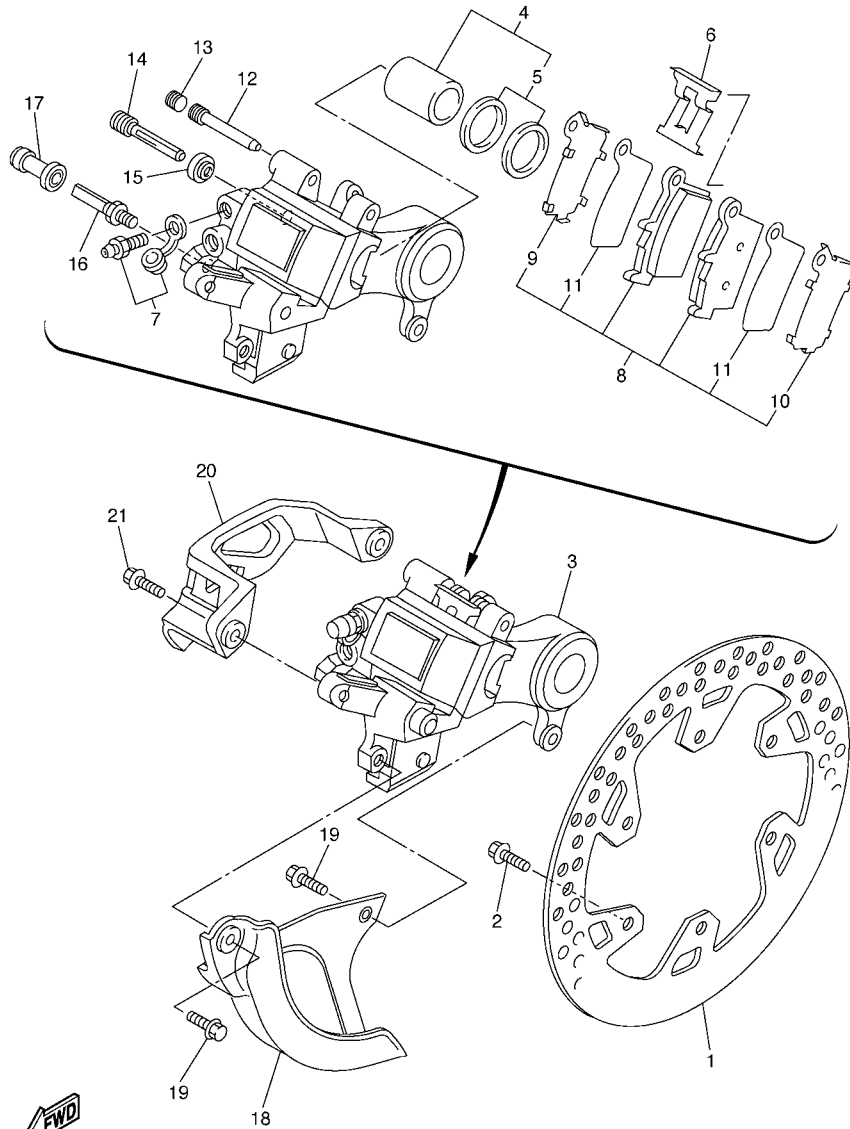

5XD1100-C310

FIG. 31 REAR BRAKE CALIPER

REF. NO.	PART NO.	DESCRIPTION	5XC1	5XC2	5XC3	5XC4	REMARKS
1	5NY-2582W-00	DISC, REAR BRAKE 2	1	1	1	1	
2	90109-065G4	BOLT	6	6	6	6	
3	5UN-2580W-20	CALIPER ASSY, REAR 2	1	1	1	1	
4	5UN-W0057-50	.PISTON ASSY, CALIPER	1	1	1	1	
5	5UN-W0047-50	..CALIPER SEAL KIT	1	1	1	1	
6	5DH-25919-50	..SUPPORT, PAD	1	1	1	1	
7	1UY-W0048-50	.BLEED SCREW KIT	1	1	1	1	
8	5UN-W0046-60	.BRAKE PAD KIT 2	1	1	1	1	
9	5UN-25828-60	..SHIM, CALIPER	1	1	1	1	
10	5UN-25827-60	..SHIM, CALIPER	1	1	1	1	
11	5UN-22898-60	..INSULATOR, HEAT	2	2	2	2	
12	8CR-25924-00	.PIN, PAD	1	1	1	1	
13	5DH-25916-00	.PLUG	1	1	1	1	
14	5DH-25914-50	.PIN, SLIDE	1	1	1	1	
15	3JD-25917-00	.BOOT, CALIPER	1	1	1	1	
16	5UN-25914-00	.PIN, SLIDE	1	1	1	1	
17	1UY-25937-51	.BOOT 2	1	1	1	1	
18	5DH-25718-01	PROTECTOR, DISK BRAKE	1	1	1	1	
19	95027-06012	BOLT, FLANGE	2	2	2	2	
20	5TA-27491-00	PROTECTOR	1	1	1	1	
21	95027-06016	BOLT, FLANGE	2	2	2	2	

FIG. 32 STEERING HANDLE & CABLE

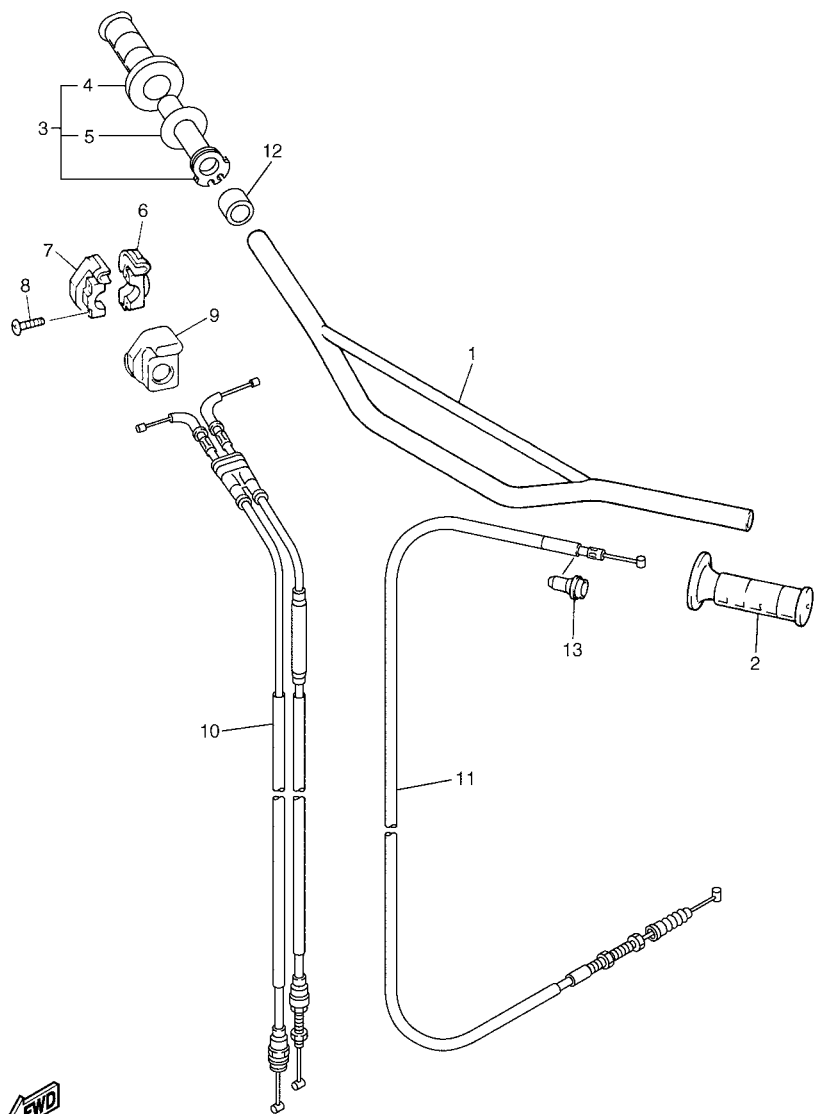

5UL1100-B320

REF. NO.	PART NO.	DESCRIPTION	5XC1	5XC2	5XC3	5XC4	REMARKS
1	4XM-26111-00	HANDLEBAR	1	1	1	1	
2	4GY-26241-00	GRIP	1	1	1	1	
3	5BE-26240-00	GRIP ASSY	1	1	1	1	
4	4GY-26242-00	.GRIP (RIGHT)	1	1	1	1	
5	3Y1-26249-00	.RING, LEAF	1	1	1	1	
6	5BE-26281-00	CAP, GRIP UPPER	1	1	1	1	
7	5BE-26282-00	CAP, GRIP LOWER	1	1	1	1	
8	98507-05020	SCREW, PAN HEAD	2	2	2	2	
9	5SF-26287-00	COVER, CAP GRIP	1	1	1	1	
10	5XD-26302-00	THROTTLE CABLE ASSY	1	1	1	1	
11	5UL-26335-00	CABLE, CLUTCH	1	1	1	1	
12	90387-225N2	COLLAR	1	1	1	1	
13	5HD-26342-00	BOOT, CABLE	1	1	1	1	

FIG. 33 FRONT MASTER CYLINDER

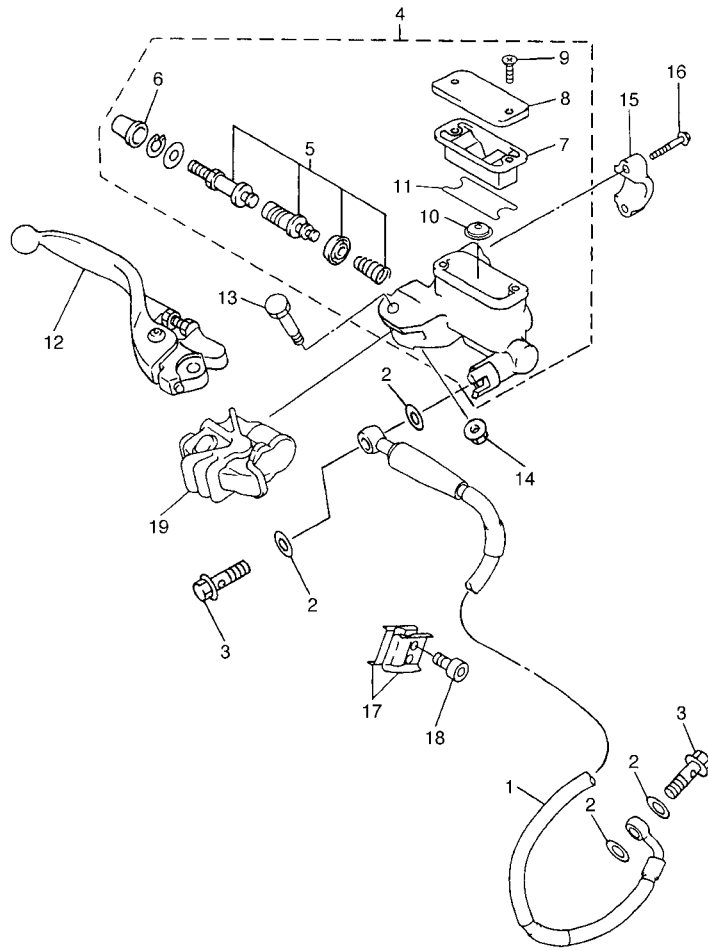

REF. NO.	PART NO.	DESCRIPTION	5XC1	5XC2	5XC3	5XC4	REMARKS
1	5ET-25872-00	HOSE, BRAKE 1	1	1	1	1	
2	90201-10118	WASHER, PLATE	4	4	4	4	
3	90401-10172	BOLT, UNION	2	2	2	2	
4	5XE-W2587-00	MASTER CYLINDER SUB ASSY	1	1	1	1	
5	5NY-W0041-00	.CYLINDER KIT, MASTER	1	1	1	1	
6	5NY-25868-00	.BOOT, MASTER CYLINDER	1	1	1	1	
7	5XE-25854-00	.DIAPHRAGM, RESERVOIR	1	1	1	1	
8	5MV-25852-01	.CAP, RESERVOIR	1	1	1	1	
9	98706-04012	.SCREW, FLAT HEAD	2	2	2	2	
10	5CG-25715-00	.SEPARATOR ASSY	1	1	1	1	
11	5XE-25853-00	.FLOAT, RESERVOIR	1	1	1	1	
12	5MV-83922-00	LEVER 2	1	1	1	1	
13	5MV-2589F-00	BOLT, LEVER	1	1	1	1	
14	95701-06500	NUT, FLANGE	1	1	1	1	
15	5MV-25867-00	BRACKET, MASTER CYLINDER	1	1	1	1	
16	5MV-25833-00	BOLT, FITTING	2	2	2	2	
17	90465-16258	CLAMP	2	2	2	2	
18	91317-06014	BOLT	2	2	2	2	
19	5NY-26372-00	COVER, HANDLE LEVER 1	1	1	1	1	



5XD1100-C330

FIG. 34 STAND & FOOTREST

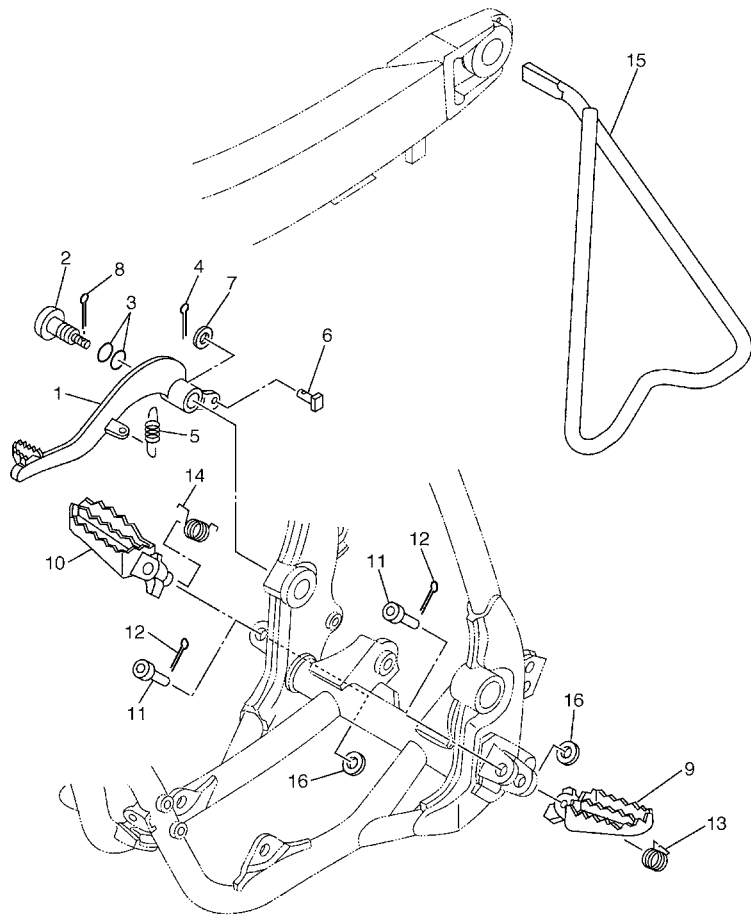

REF. NO.	PART NO.	DESCRIPTION	5XC1	5XC2	5XC3	5XC4	REMARKS
1	4XM-27200-00	PEDAL, BRAKE	1	1	1	1	
2	5JG-27217-00	BOLT	1	1	1	1	
3	93210-11073	O-RING	2	2	2	2	
4	91401-20012	PIN, COTTER	1	1	1	1	
5	90506-16500	SPRING, TENSION	1	1	1	1	
6	90240-08120	PIN, CLEVIS	1	1	1	1	
7	90201-08089	WASHER, PLATE	1	1	1	1	
8	90468-16191	CLIP	1	1	1	1	
9	5XE-27411-00	FOOTREST 1	1	1	1	1	
10	5XE-27421-00	FOOTREST 2	1	1	1	1	
11	90240-10142	PIN, CLEVIS	2	2	2	2	
12	91401-25015	PIN, COTTER	2	2	2	2	
13	90508-282B8	SPRING, TORSION	1	1	1	1	
14	90508-282B9	SPRING, TORSION	1	1	1	1	
15	5ET-27311-00	STAND, SIDE	1	1	1	1	
16	90201-10119	WASHER, PLATE	2	2	2	2	



5XC1100-C340

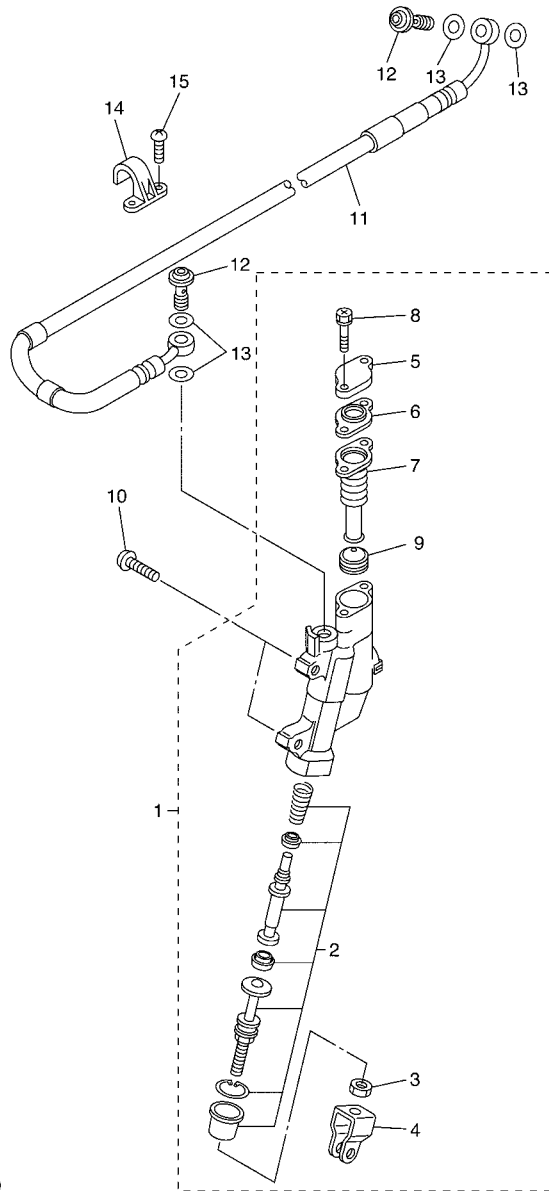

5TA1100-B350

FIG. 35 REAR MASTER CYLINDER

REF. NO.	PART NO.	DESCRIPTION	5XC1	5XC2	5XC3	5XC4	REMARKS
1	5UN-2583V-00	RR. MASTER CYLINDER ASSY.	1	1	1	1	
2	5UN-W0042-50	.CYLINDER KIT, MASTER	1	1	1	1	
3	5UN-27218-00	.NUT	1	1	1	1	
4	5UN-27222-00	.JOINT	1	1	1	1	
5	5UN-25852-50	.CAP, RESERVOIR	1	1	1	1	
6	5UN-2585B-00	.PLATE, DIAPHRAGM	1	1	1	1	
7	5UN-25854-00	.DIAPHRAGM, RESERVOIR	1	1	1	1	
8	5UN-27217-00	.BOLT	2	2	2	2	
9	5CG-25715-00	.SEPARATOR ASSY	2	2	2	2	
10	90111-06029	BOLT	2	2	2	2	
11	5UN-25873-00	HOSE, BRAKE 2	1	1	1	1	
12	90401-10172	BOLT, UNION	2	2	2	2	
13	90201-10118	WASHER, PLATE	4	4	4	4	
14	2VM-25876-00	HOLDER, BRAKE HOSE 2	2	2	2	2	
15	98507-05010	SCREW, PAN HEAD	4	4	4	4	

FIG. 36 GENERATOR

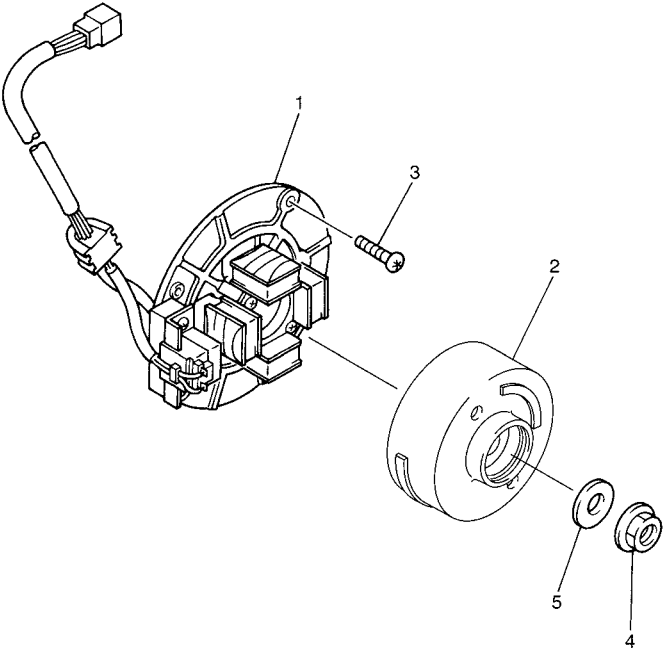

REF. NO.	PART NO.	DESCRIPTION					REMARKS
			5XC1	5XC2	5XC3	5XC4	
1	5SF-85560-00	BASE ASSY	1	1	1	1	
2	5TA-85550-00	ROTOR ASSY	1	1	1	1	
3	90149-06324	SCREW	3	3	3	3	
4	90179-12248	NUT	1	1	1	1	
5	90201-127E1	WASHER, PLATE	1	1	1	1	

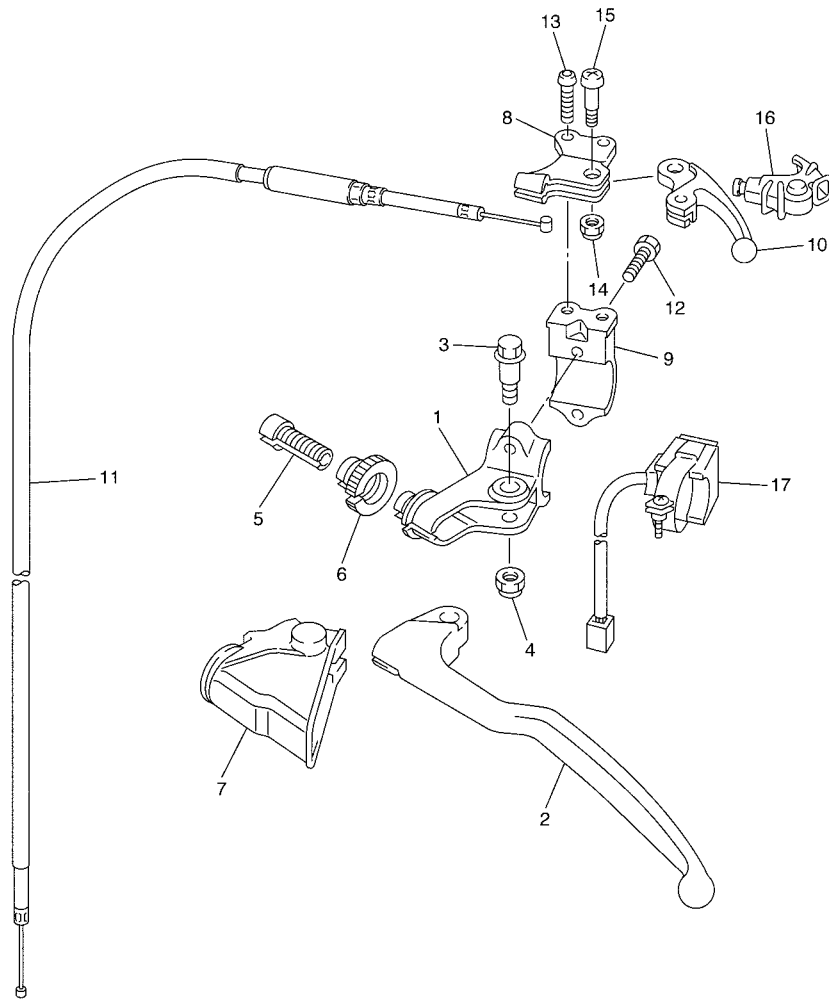

5TA1100-B370

FIG. 37 HANDLE SWITCH & LEVER

REF. NO.	PART NO.	DESCRIPTION	5XC1	5XC2	5XC3	5XC4	REMARKS
1	5XE-82911-00	HOLDER, LEVER 1	1	1	1	1	
2	5MV-83912-00	LEVER 1	1	1	1	1	
3	90109-06034	BOLT	1	1	1	1	
4	5LP-84126-10	NUT, LENS FITTING	1	1	1	1	
5	5TA-26337-00	BOLT, ADJUSTING	1	1	1	1	
6	5HD-83951-00	BOLT, CABLE ADJUSTING	1	1	1	1	
7	5HD-26372-00	COVER, HANDLE LEVER 1	1	1	1	1	
8	5XD-82946-00	HOLDER, STARTER LEVER	1	1	1	1	
9	5XD-82913-00	HOLDER, LEVER LOWER 1	1	1	1	1	
10	5TA-83941-00	LEVER, STARTER	1	1	1	1	
11	5TA-26334-00	CABLE, STARTER 2	1	1	1	1	
12	90101-05033	BOLT	2	2	2	2	
13	92014-05012	BOLT, BUTTON HEAD	2	2	2	2	
14	95607-05100	NUT, U	1	1	1	1	
15	90149-05162	SCREW	1	1	1	1	
16	5TA-26339-00	BOOT	1	1	1	1	
17	5SF-83976-00	SWITCH, HANDLE 1	1	1	1	1	

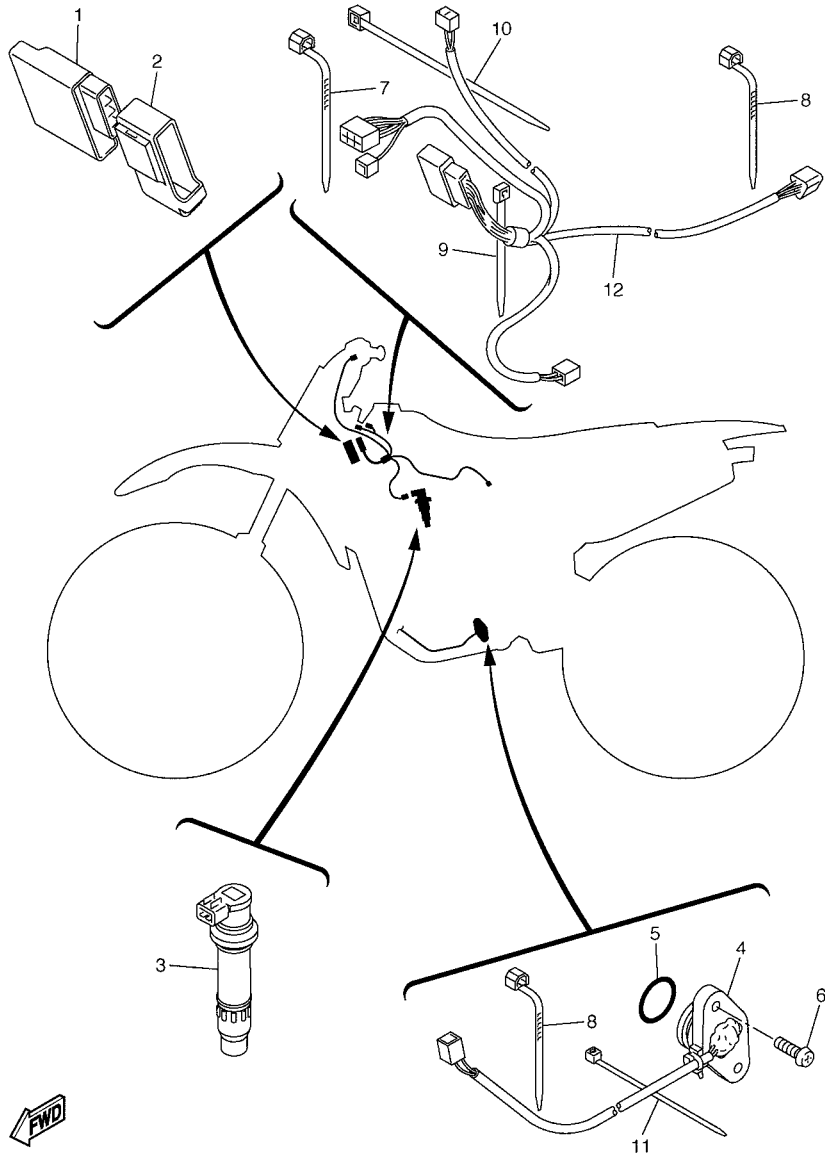

5XC1100-C380

FIG. 38 ELECTRICAL 1

REF. NO.	PART NO.	DESCRIPTION	5XC1	5XC2	5XC3	5XC4	REMARKS
1	5XC-85540-00	C.D.I. UNIT ASSY	1	1	1	1	
2	5TA-85546-00	BAND	1	1	1	1	
3	5UL-82310-10	IGNITION COIL ASSY	1	1	1	1	
4	5TA-82540-00	NEUTRAL SWITCH ASSY	1	1	1	1	
5	93210-21276	O-RING	1	1	1	1	
6	90154-05026	SCREW, BINDING	2	2	2	2	
7	90464-13077	CLAMP	2	2	2	2	
8	90464-13073	CLAMP	3	3	3	3	
9	90465-13152	CLAMP	1	1	1	1	
10	90465-13275	CLAMP	4	4	4	4	
11	5Y9-12491-00	CLAMP 1	3	3	3	3	
12	5TA-82509-01	WIRE, SUB LEAD	1	1	1	1	

FIG. 39 ALTERNATE FOR CHASSIS

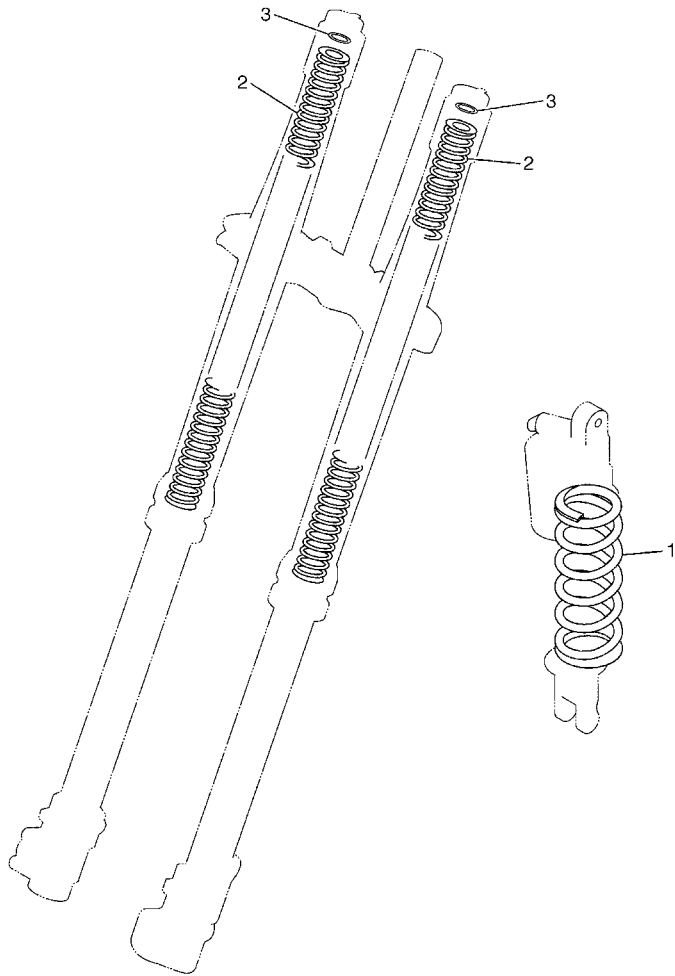

5XC1100-C390

REF. NO.	PART NO.	DESCRIPTION	5XC1	5XC2	5XC3	5XC4	REMARKS
1	5UN-22212-00	SPRING (K=42N/MM)	1	1	1	1	AP
	5UN-22212-10	SPRING (K=44N/MM)	1	1	1	1	AP
	5UN-22212-20	SPRING (K=46N/MM)	1	1	1	1	AP
	5UN-22212-30	SPRING (K=48N/MM)	1	1	1	1	AP
	5UN-22212-40	SPRING (K=50N/MM)	1	1	1	1	AP
	5UN-22212-50	SPRING (K=52N/MM)	1	1	1	1	AP
	5UN-22212-60	SPRING (K=54N/MM)	1	1	1	1	AP
	5UN-22212-70	SPRING (K=56N/MM)	1	1	1	1	AP
	5UN-22212-A0	SPRING (K=APPROX.44N/MM)	1	1	1	1	AP
	5UN-22212-B0	SPRING (K=APPROX.46N/MM)	1	1	1	1	AP
	5UN-22212-C0	SPRING (K=APPROX.48N/MM)	1	1	1	1	AP
	5UN-22212-D0	SPRING (K=APPROX.50N/MM)	1	1	1	1	AP
	5UN-22212-E0	SPRING (K=APPROX.52N/MM)	1	1	1	1	AP
5UN-22212-F0	SPRING (K=APPROX.54N/MM)	1	1	1	1	AP	
5UN-22212-G0	SPRING (K=APPROX.56N/MM)	1	1	1	1	AP	
2	5XE-23141-00	SPRING (K=3.9N/MM)	2	2	2	2	AP
	5XE-23141-10	SPRING (K=4.0N/MM)	2	2	2	2	AP
	5XE-23141-20	SPRING (K=4.1N/MM)	2	2	2	2	AP
	5XE-23141-30	SPRING (K=4.2N/MM)	2	2	2	2	AP
	5XE-23141-40	SPRING (K=4.3N/MM)	2	2	2	2	AP
	5XE-23141-50	SPRING (K=4.4N/MM)	2	2	2	2	AP
	5XE-23141-60	SPRING (K=4.5N/MM)	2	2	2	2	AP
	5XE-23141-70	SPRING (K=4.6N/MM)	2	2	2	2	AP
	5XE-23141-80	SPRING (K=4.7N/MM)	2	2	2	2	AP
	5XE-23141-A0	SPRING (K=APPROX.3.9N/MM)	2	2	2	2	AP
5XE-23141-B0	SPRING (K=APPROX.4.1N/MM)	2	2	2	2	AP	
5XE-23141-C0	SPRING (K=APPROX.4.3N/MM)	2	2	2	2	AP	

FIG. 39 ALTERNATE FOR CHASSIS

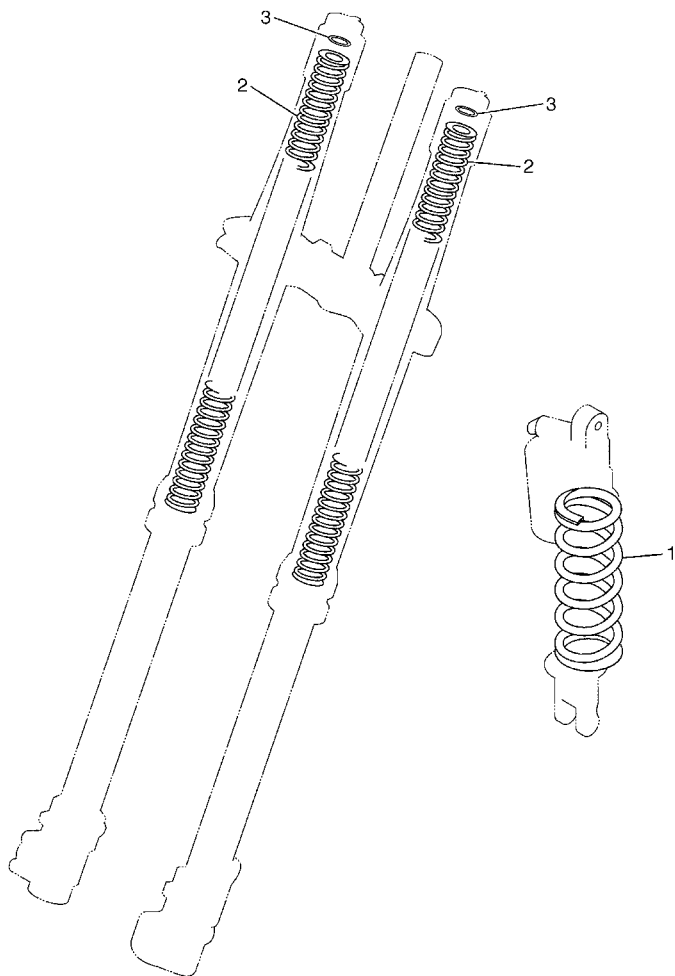

REF. NO.	PART NO.	DESCRIPTION	5XC1	5XC2	5XC3	5XC4	REMARKS
2	5XE-23141-D0	SPRING (K=APPROX.4.5N/MM)	2	2	2	2	AP
	5XE-23141-E0	SPRING (K=APPROX.4.7N/MM)	2	2	2	2	AP
3	5XE-23364-00	COLLAR 2	1	1	1	1	UN AP

5XC1100-C390

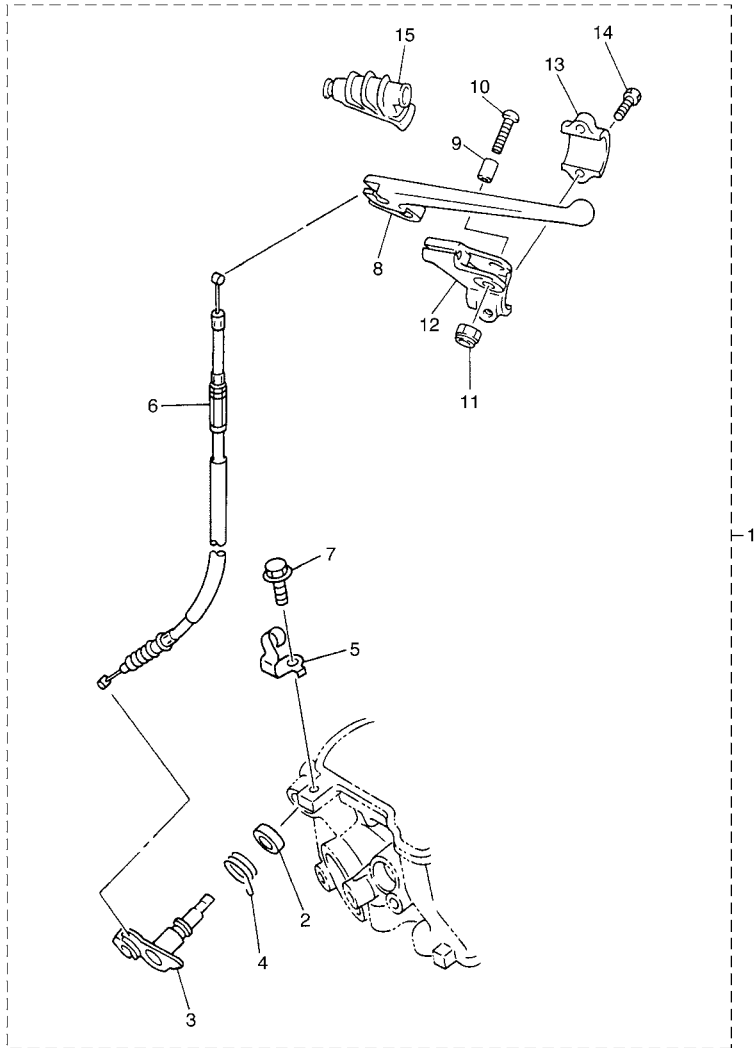

5TA1100-B400

FIG. 40 ALTERNATE DECOMPRESSION KIT

REF. NO.	PART NO.	DESCRIPTION	5XC1	5XC2	5XC3	5XC4	REMARKS
1	5TA-W1228-00	DECOMPRESSION KIT	1	1	1	1	AP
2	93102-12224	.OIL SEAL	1	1	1	1	
3	5BE-12280-10	.DECOMPRESSION ASSY	1	1	1	1	
4	90508-162B2	.SPRING, TORSION	1	1	1	1	
5	5NL-12283-00	.BRACKET, DECOMPRESSION	1	1	1	1	
6	5BE-12292-10	.CABLE, DECOMPRESSION	1	1	1	1	
7	95827-06014	.BOLT, FLANGE	1	1	1	1	
8	583-83981-00	.LEVER, DECOMPRESSION	1	1	1	1	
9	5BE-83913-00	.COLLAR, LEVER 1	1	1	1	1	
10	98507-05020	.SCREW, PAN HEAD	1	1	1	1	
11	95607-05100	.NUT, U	1	1	1	1	
12	5BE-82912-00	.HOLDER, LEVER UPPER 1	1	1	1	1	
13	38V-82913-00	.HOLDER, LEVER LOWER 1	1	1	1	1	
14	97007-05016	.BOLT	2	2	2	2	
15	583-26352-00	.COVER, DECOMPRESSION CABLE	1	1	1	1	

NUMERICAL INDEX

PART NO.	GRID NO.	PART NO.	GRID NO.	PART NO.	GRID NO.	PART NO.	GRID NO.	PART NO.	GRID NO.	PART NO.	GRID NO.
5NL-11102-20	B - 2	1HX-12168-F0	B - 5	5NL-13341-00	B - 10	5JG-14521-00	B - 13	4MX-14948-04	B - 14	4GY-15671-00	C - 7
4KG-1111G-00	B - 3	1HX-12168-H1	B - 5	5BE-13342-00	B - 10	5JG-14522-00	B - 13	4MX-14948-05	B - 14	214-15686-00	C - 7
5NL-11133-10	B - 2	1HX-12168-K1	B - 5	5NL-13411-00	B - 10	5JG-14531-00	C - 2	4MX-14948-06	B - 14	5NL-16111-00	C - 8
5NL-11134-10	B - 2	1HX-12168-M1	B - 5	5NL-13412-00	B - 10	3TJ-14536-40	B - 15	4JT-1494F-11	B - 14	5NL-16150-10	C - 8
5TA-11166-00	B - 2	1HX-12168-R1	B - 5	5TA-13440-00	B - 11	5JG-14546-01	B - 13	3TJ-1494F-13	B - 14	5NL-16154-00	C - 8
5BE-11167-00	B - 2	1HX-12168-U1	B - 5	5BE-13447-10	B - 11	676-14548-00	B - 15	3TJ-1494F-14	B - 14	3XJ-16321-00	C - 8
371-11167-01	B - 2	1HX-12168-W1	B - 5	5XC-13464-00	B - 10	4MX-14561-00	C - 2	3TJ-1494F-15	B - 14	5DH-16321-00	C - 8
5NL-11181-00	B - 2	1HX-12168-Y1	B - 5	5XC-13465-00	B - 10	6H4-14561-00	B - 15	4JT-1494F-15	B - 14	5NL-16325-00	C - 8
5NL-11191-00	B - 2	1HX-12169-11	B - 6	5UL-13597-00	B - 12	5NX-14562-00	B - 15	3TJ-1494F-16	B - 14	5NL-16325-10	C - 8
5NL-11193-00	B - 3	1HX-12169-31	B - 6	5XC-14101-00	B - 13	5JG-14565-00	C - 2	3TJ-1494F-17	B - 14	5HD-16351-00	C - 8
5XC-11311-00	B - 3	1HX-12169-50	B - 6	3TJ-14105-40	B - 14	5JG-14591-00	C - 2	3TJ-1494F-18	B - 14	5NL-16356-00	C - 8
5NL-11351-00	B - 3	1HX-12169-70	B - 6	4MX-14115-00	C - 2	688-14592-00	B - 13	3TJ-1494F-19	B - 14	5NL-16357-00	C - 8
5UM-11387-00	B - 3	1HX-12169-90	B - 6	3TJ-14137-40	B - 12	5XC-14611-00	C - 3	4JT-1494F-19	B - 14	5NL-16371-00	C - 8
5XC-11400-00	B - 4	1HX-12169-E0	B - 6			5NL-14613-00	C - 3	4JT-1494F-23	B - 14	5JG-16381-00	C - 8
5UL-11412-10	B - 4	1HX-12169-G0	B - 6	5BE-14146-00	C - 2	5XC-14628-00	C - 3	4JT-1494F-27	B - 14	5NL-16383-10	C - 8
5UL-11422-00	B - 4	1HX-12169-J0	B - 6	5PA-14146-00	C - 2	5NL-1469A-00	C - 3	4JT-1494F-29	B - 14	4JT-16384-00	C - 8
5NL-11454-00	B - 4	1HX-12169-L0	B - 6	5TA-14155-00	B - 15	5BE-1469E-00	C - 3	4JT-1494F-31	B - 14	5NL-16384-00	C - 8
5NL-11455-00	B - 4	1HX-12169-N0	B - 6	633-14159-00	B - 15	5BE-14747-00	C - 3	5JG-14951-00	B - 13	5NL-17121-00	C - 10
5NL-11531-00	B - 4	1HX-12169-T0	B - 6	3TJ-14159-40	B - 13	3VD-14755-00	C - 3	5JG-14959-00	B - 13	5NL-17131-10	C - 10
5NL-11536-00	B - 4	5UL-12170-00	B - 7	5TA-14171-00	B - 15	4BD-14766-00	C - 3	5JG-14984-00	B - 15	5NL-17141-10	C - 10
5NL-11603-00	B - 4	5UL-12180-00	B - 7	5UL-14191-40	B - 15	5UL-14788-00	C - 3	4SR-14985-00	B - 15	5NL-17151-00	C - 10
5NL-11631-10	B - 4	5TA-12210-00	B - 7	5TA-14196-00	C - 2	5JG-14916-E1	B - 13	5TA-14987-00	B - 12	5NL-17211-10	C - 10
5NL-11633-00	B - 4	4FM-12213-00	B - 7	5TA-14197-00	C - 2	5JG-14916-EN	B - 13	5TJ-14987-00	C - 2	5NL-17221-00	C - 10
5UL-11651-00	B - 4	5BE-12241-00	B - 7	5NX-14216-00	C - 2	5JG-14916-EP	B - 13	5TA-14991-00	B - 15	5NL-17231-10	C - 10
5XC-11681-00	B - 4	5NL-12251-00	B - 7	5TA-14227-00	B - 12	5JG-14916-ER	B - 13	4FN-14997-00	B - 13	5NL-17241-10	C - 10
5NL-12111-10	B - 5	5NL-12252-00	B - 7	5TA-14239-00	B - 12	5JG-14916-ES	B - 13	5TA-14997-00	B - 15	5NL-17251-10	C - 10
5NL-12112-10	B - 5	5BE-12280-10	E - 14	5TA-14261-00	C - 2	5JG-14916-ET	B - 13	5XC-15150-00	C - 4	5NL-17402-00	C - 10
5NL-12113-00	B - 5	5NL-12283-00	E - 14	5JG-14264-00	B - 13	5JG-14916-EU	B - 13	5UL-15362-01	C - 15	5NL-17411-10	C - 10
5NL-12114-00	B - 5	5BE-12292-10	E - 14	3TJ-14267-40	B - 13	5JG-14922-00	B - 15	3Y1-15363-00	C - 5	5NL-17466-00	C - 4
5NL-12116-00	B - 5	5NL-1240A-10	B - 9	5JG-14275-00	B - 13	3TJ-14933-40	B - 15	5XD-15378-00	C - 6	5NL-17471-00	C - 11
1HX-12117-00	B - 5	5NL-12422-10	B - 8	5TA-14293-00	B - 12	5TA-14934-00	B - 15	4JT-15381-01	C - 4	5UL-18101-00	C - 13
1WG-12117-00	B - 5	5NL-12439-00	B - 8	3TJ-14293-40	B - 15	5JG-14940-16	B - 15	5BE-15383-01	C - 4	5UL-18110-00	C - 13
1HX-12118-00	B - 5	5DH-12451-00	B - 8	5TA-14335-00	B - 15	5JG-14940-17	B - 15	5NL-15388-00	C - 4	5LP-18122-00	C - 13
1WG-12118-00	B - 5	5XC-12459-00	B - 8	5JG-14346-00	C - 2	5JG-14940-18	B - 15	5NL-15411-10	C - 5	3XK-18140-00	C - 12
4SV-12119-00	B - 5	5NL-12461-10	B - 9	5TA-14371-00	B - 15	5JG-14940-76	B - 15	5NL-15415-00	C - 5	5BE-18172-00	C - 13
4TV-12119-00	B - 5	5HD-12462-00	B - 9	5TA-14374-00	B - 15	5TA-14943-27	B - 14	5BE-15421-01	C - 4	3XJ-18173-00	C - 13
5NL-12121-10	B - 5	5NL-12481-00	B - 9	5JG-14379-00	B - 15	4MX-14943-41	B - 13	5NL-15431-10	C - 5	3XJ-18178-00	C - 13
3GM-12126-00	B - 5	5Y9-12491-00	E - 11	5JG-14388-00	B - 13	4MX-14943-42	B - 14	5NL-15441-01	C - 4	3XJ-18182-00	C - 13
3FV-12153-09	B - 6	5NL-12564-00	C - 5	4MX-14392-00	B - 15	4MX-14943-43	B - 13	5NL-15451-00	C - 5	3XJ-18184-00	C - 13
3LN-12153-09	B - 6	5SG-12576-00	B - 9	5TA-14401-01	B - 12	4MX-14943-44	B - 14	5NL-15453-00	C - 5	4EW-18185-00	C - 13
3FV-12153-10	B - 6	5SG-12577-00	B - 9	5XD-14417-00	B - 12	4MX-14943-45	B - 14	5NL-15462-00	C - 5	5NL-18501-00	C - 12
3LN-12153-10	B - 6	5SG-12578-00	B - 9	5TA-14428-00	B - 12	4MX-14943-92	B - 13	5NL-15601-00	C - 7	5NL-18502-00	C - 12
1HX-12168-00	B - 5	5SG-12579-00	B - 9	5NY-14442-00	B - 12	4MX-14943-93	B - 14	5NL-15620-10	C - 7	5NL-18503-00	C - 12
1HX-12168-20	B - 5	583-13113-00	B - 11	4XM-14451-00	B - 12	4MX-14943-94	B - 14	5NX-15621-10	C - 7	5NL-18541-00	C - 12
1HX-12168-40	B - 5	5NL-13161-00	B - 11	5TA-14453-00	B - 12	4MX-14943-95	B - 14	5NL-15641-00	C - 7	4BA-18542-00	C - 12
1HX-12168-60	B - 5	5NL-13171-00	B - 11	5NY-14455-10	B - 12	5JG-14947-00	B - 13	5NL-15651-00	C - 7	5DH-18562-00	C - 4
1HX-12168-80	B - 5	5SG-13300-00	B - 10	5BE-14458-00	B - 12	4MX-14948-02	B - 14	5NL-15664-00	C - 7	5XC-21101-00	C - 14
1HX-12168-A0	B - 5	5NL-13320-00	B - 10	5NY-14459-00	B - 12	4MX-14948-03	B - 14	5SG-15668-00	C - 7	5XD-21190-00	C - 14

NUMERICAL INDEX

PART NO.	GRID NO.	PART NO.	GRID NO.	PART NO.	GRID NO.	PART NO.	GRID NO.	PART NO.	GRID NO.	PART NO.	GRID NO.
5TA-21274-01	C - 15	5XC-22201-40	D - 6	5XE-23120-L0	D - 9	5XD-24110-00	D - 11	5UN-25827-60	E - 4	5HD-26372-00	E - 10
5HD-2135F-00	D - 5	5XC-22210-00	D - 6	5XE-23125-L0	D - 9	4EW-2412F-00	D - 11	5UN-25828-60	E - 4	5NY-26372-00	E - 6
5XE-2135F-00	D - 5	5XC-22210-10	D - 6	3JD-2312G-L0	D - 9	5XE-24144-00	D - 11	5NY-2582W-00	E - 4	4XM-27200-00	E - 7
5UL-21417-00	C - 15	5XC-22210-20	D - 6	5XD-23136-L0	D - 9	5SF-24173-00	D - 11	5MV-25833-00	E - 6	5JG-27217-00	E - 7
5UL-21417-10	C - 15	5XC-22210-30	D - 6	5XE-24176-00	E - 12	5XE-24176-00	D - 11	5UN-2583V-00	E - 8	5UN-27217-00	E - 8
5NL-21425-00	C - 14	5XC-22210-40	D - 6	5XE-23141-10	E - 12	22W-24181-00	C - 3	5DH-25849-00	D - 15	5UN-27218-00	E - 8
5NL-21425-10	C - 14	5UN-22212-00	E - 12	5XE-23141-20	E - 12	4SS-24181-00	D - 11	5MV-25852-01	E - 6	5UN-27222-00	E - 8
5NL-21471-01	C - 15	5UN-22212-10	E - 12	5XE-23141-30	E - 12	5BE-24182-00	D - 11	5UN-25852-50	E - 8	5ET-27311-00	E - 7
5NL-2147A-00	C - 15	5UN-22212-20	D - 6	5XE-23141-40	E - 12	5NY-24183-00	D - 11	5XE-25853-00	E - 6	5XE-27411-00	E - 7
5HD-21511-00	D - 2		E - 12	5XE-23141-50	E - 12	5NY-24186-00	D - 11	5UN-25854-00	E - 8	5XE-27421-00	E - 7
5UN-2153A-00	D - 5	5UN-22212-30	E - 12	5XE-23141-60	E - 12	5XD-24240-00	D - 12	5XE-25854-00	E - 6	5TA-27491-00	E - 4
4XL-2153A-10	D - 10	5UN-22212-40	E - 12	5XE-23141-70	E - 12	3XJ-24380-00	D - 11	5UN-2585B-00	E - 8	5TA-2814F-00	C - 15
4ES-2153E-01	D - 2	5UN-22212-50	E - 12	5XE-23141-80	E - 12	4DP-24500-00	D - 11	5MV-25867-00	E - 6	5ET-28166-00	C - 15
5XD-21610-00	D - 2	5UN-22212-60	E - 12	5XE-23141-A0	E - 12	4X8-24512-00	D - 11	5NY-25868-00	E - 6	5UL-82310-10	E - 11
5XD-21635-00	D - 2	5UN-22212-70	E - 12	5XE-23141-B0	E - 12	3AJ-24523-00	D - 11	5ET-25872-00	E - 6	5TA-82509-01	E - 11
5XC-2163G-00	D - 2	5UN-22212-A0	E - 12	5XE-23141-C0	E - 12	3AJ-24534-00	D - 11	5UN-25873-00	E - 8	5TA-82540-00	E - 11
5TA-21642-00	D - 2	5UN-22212-B0	E - 12	5XE-23141-D0	E - 13	5NY-24610-00	D - 11	5DH-25875-00	D - 15	5XE-82911-00	E - 10
5TA-21711-00	D - 3	5UN-22212-C0	D - 6	5XE-23141-E0	E - 13	5XD-2470F-00	D - 13	2VM-25876-00	E - 8	5BE-82912-00	E - 14
5TA-21721-00	D - 3		E - 12	5XC-23141-L0	D - 9	5XD-24710-00	D - 13	5MV-2589F-00	E - 6	38V-82913-00	E - 14
5NL-2172A-11	D - 3	5UN-22212-D0	E - 12	5XE-23142-L0	D - 9	5NY-25104-00	D - 14	5UN-25914-00	E - 4	5XD-82913-00	E - 10
5TA-21730-00	D - 3	5UN-22212-E0	E - 12	5XE-23144-L0	D - 9	5NY-25111-00	D - 14	5DH-25914-50	E - 4	5XD-82946-00	E - 10
5XD-2173E-00	D - 3	5UN-22212-F0	E - 12	5XE-23145-L0	D - 9	5NY-25117-00	D - 14	3SP-25914-51	D - 15	5MV-83912-00	E - 10
5XD-2173F-00	D - 3	5UN-22212-G0	E - 12	5XE-23146-L0	D - 9	5BE-25181-00	D - 14	5DH-25916-00	D - 15	5BE-83913-00	E - 14
5TA-21740-00	D - 3	3SP-22213-00	D - 6	5DH-2314E-00	D - 15	5NY-25183-00	D - 14		E - 4	5MV-83922-00	E - 6
3JD-21748-00	D - 2	5XE-22214-00	D - 6	5XE-2314F-L0	D - 10	5NY-25186-00	D - 14	3JD-25917-00	D - 15	5TA-83941-00	E - 10
5TA-2174A-00	D - 3	5MV-22224-00	D - 6	5XE-2314G-L0	D - 10	5HD-25304-00	E - 2		E - 4	5HD-83951-00	E - 10
5TA-2174T-00	D - 2	3SP-22234-00	D - 6	5TA-2314H-00	D - 10	5ET-25311-00	E - 2	5DH-25919-00	D - 15	5SF-83976-00	E - 10
5TA-21756-00	C - 14	5NY-22241-00	D - 7	5TA-2314J-00	D - 10	5ET-25317-00	E - 2	5DH-25919-50	E - 4	583-83981-00	E - 14
5MV-2175C-00	D - 3	5XE-22242-00	D - 7	5XE-23153-L0	D - 9	4XM-25364-00	E - 2	8CR-25924-00	E - 4	5LP-84126-10	E - 10
5XD-21781-00	D - 3	5DH-22253-00	D - 6	4SS-23158-L0	D - 9	5ET-25367-00	E - 3	3SP-25926-51	D - 15	5XC-85540-00	E - 11
5UN-22110-00	D - 4	5MV-22253-00	D - 6	5XC-2316A-L0	D - 9	5ET-25381-00	E - 3	5DH-25933-00	D - 15	5TA-85546-00	E - 11
5NY-22121-00	D - 4	4AA-22259-40	D - 6	5XC-2316A-M0	D - 9	5UN-25383-00	E - 3	1UY-25937-51	D - 15	5TA-85550-00	E - 9
5XE-22122-00	D - 5	4AA-22259-50	D - 6	5XC-23170-L0	D - 9	5NY-25388-00	E - 3		E - 4	5SF-85560-00	E - 9
5UN-22128-00	D - 4	4AA-22259-60	D - 6	5XE-23171-L0	D - 9	5NY-25389-00	E - 3	4XM-26111-00	E - 5	5TA-85885-00	B - 15
5NY-22141-01	D - 4	4AA-22259-80	D - 6	5TJ-2319U-00	D - 8	4XM-25394-00	E - 2	5BE-26240-00	E - 5	5NY-W0041-00	E - 6
5UN-22151-00	D - 4	5UN-22355-00	D - 4	5XC-23340-L0	D - 10	5SF-25394-00	D - 14	4GY-26241-00	E - 5	5UN-W0042-50	E - 8
5JG-22156-00	D - 4	4EW-22474-00	D - 6	4SS-23346-L0	D - 10	5ET-25447-00	E - 2	4GY-26242-00	E - 5	5MV-W0045-01	D - 15
5UN-22176-00	D - 6	3JE-22475-00	D - 6	5NY-23346-L0	D - 10	5NY-25448-00	E - 2	3Y1-26249-00	E - 5	5UN-W0046-60	E - 4
4EW-22178-00	C - 14	5NY-22475-00	D - 6	3SP-23356-L0	D - 10	5NY-25449-00	E - 2	5BE-26281-00	E - 5	3JD-W0047-00	D - 15
3JD-22178-10	C - 14	5UN-22898-60	E - 4	5TA-23357-00	D - 8	5NY-25450-00	E - 2	5BE-26282-00	E - 5	5UN-W0047-50	E - 4
5NY-2217A-00	D - 4	5XC-23102-00	D - 9	5XE-23364-00	E - 13	5NY-25451-00	E - 3	5SF-26287-00	E - 5	1UY-W0048-50	D - 15
5XE-2217F-00	D - 5	5XC-23102-10	D - 9	5XE-23389-00	D - 8	5XD-25452-00	E - 3	5XD-26302-00	E - 5		E - 4
5MV-22184-00	D - 6	5XC-23103-00	D - 9	5XE-23393-L0	D - 9	5CG-25715-00	E - 6	5TA-26334-00	E - 10	5UN-W0057-00	D - 15
5UN-22199-00	D - 4	5XC-23103-10	D - 9	5HD-2339E-00	D - 8		E - 8	5UL-26335-00	E - 5	5UN-W0057-50	E - 4
5XC-22201-00	D - 6	5XE-23110-L0	D - 9	4EW-23416-00	D - 8	5DH-25718-01	E - 4	5TA-26337-00	E - 10	5TA-W1228-00	E - 14
5XC-22201-10	D - 6	5XE-23111-L0	D - 9	5XE-23435-00	D - 8	5UN-2580T-00	D - 15	5TA-26339-00	E - 10	5XE-W2587-00	E - 6
5XC-22201-20	D - 6	5XE-23113-00	D - 8	5XE-23441-00	D - 8	5UN-2580W-20	E - 4	5HD-26342-00	E - 5	5UL-Y1475-01	C - 3
5XC-22201-30	D - 6	5XE-23117-L0	D - 9	5HD-23485-10	D - 8	5MV-2581T-00	D - 15	583-26352-00	E - 14	5UL-Y1475-11	C - 3

NUMERICAL INDEX

PART NO.	GRID NO.	PART NO.	GRID NO.	PART NO.	GRID NO.	PART NO.	GRID NO.	PART NO.	GRID NO.	PART NO.	GRID NO.
90101-05033	E - 10	90170-14171	B - 4	90209-20008	C - 10	90450-32015	B - 9	92014-05012	E - 10	93310-63238	B - 4
90101-06001	C - 7	90170-16326	C - 8	90209-23012	C - 10	90450-54002	B - 12	92017-08055	C - 14	93311-32261	B - 4
90101-06664	C - 13	90179-06568	D - 4	90215-14204	B - 4	90450-57092	B - 12	92907-06600	B - 7	93315-32053	D - 5
90101-08777	E - 3	90179-08674	C - 14	90215-16289	C - 8	90450-61001	B - 12		C - 15	93315-32056	D - 4
90105-06027	B - 2	90179-10658	C - 14	90215-20003	C - 8	90464-13073	E - 11	92907-08200	D - 15	93317-11287	C - 8
90105-06553	C - 4	90179-12248	E - 9		C - 10	90464-13077	E - 11	93101-14164	C - 5	93317-22262	D - 4
	C - 11	90179-16672	D - 14	90240-08120	E - 7	90465-08029	C - 5	93102-12106	B - 8	93332-00068	D - 8
90105-065A1	C - 5	90179-18001	C - 8	90240-10142	E - 7	90465-10013	C - 4	93102-12224	C - 8	93332-00081	D - 8
90105-08057	C - 3		C - 11	90267-32070	B - 12	90465-13152	D - 11		C - 13	93340-21008	C - 8
90105-08120	C - 14	90179-28003	D - 8	90267-48121	C - 3		E - 11		E - 14	93342-22217	D - 4
90105-08659	D - 15	90183-06023	B - 12	90280-03001	B - 4	90465-13275	E - 11	93102-18278	C - 7	93410-20038	C - 7
90105-09002	B - 2	90185-08169	E - 3	90338-18064	B - 7	90465-16258	E - 6	93102-26468	D - 14	93410-22039	C - 10
90105-09555	B - 2	90185-10060	D - 7	90338-18176	C - 14	90467-09006	B - 9	93102-28010	C - 10	93410-26067	C - 10
90105-10072	C - 14	90185-14007	D - 5	90340-12112	B - 2	90467-10008	D - 11	93106-22019	D - 4	93420-16086	B - 4
90105-10733	C - 14	90185-16127	D - 4	90340-14128	C - 5	90467-11106	B - 3	93106-30044	E - 2	93440-07149	B - 2
90109-06034	E - 10	90185-20168	E - 3	90340-32123	C - 5	90467-14015	B - 2	93106-30045	E - 2	93440-07182	B - 8
90109-063F8	C - 12	90201-03313	B - 12	90387-06009	D - 2	90468-16191	E - 7	93109-11073	B - 8		C - 8
90109-06418	B - 7	90201-06557	D - 2	90387-06065	B - 9	90480-08608	E - 3	93109-20076	D - 4	93440-10153	B - 2
90109-065G2	B - 11	90201-06571	B - 9	90387-0814J	C - 3	90480-15528	B - 9	93109-28043	D - 4		B - 10
90109-065G4	E - 4	90201-08089	E - 7	90387-086N4	C - 14	90480-18549	D - 11	93210-07003	B - 11	93440-41178	B - 7
90109-066F0	B - 3	90201-080H1	C - 8	90387-124F4	C - 13	90501-043E0	B - 11	93210-07135	B - 11	93503-08007	B - 11
90109-067F4	B - 12	90201-081R9	C - 3	90387-16005	D - 4	90501-052G5	C - 13	93210-08001	C - 15	93507-32009	C - 7
90109-081G1	E - 3	90201-08326	C - 7	90387-16007	D - 4	90501-06022	C - 12	93210-09008	B - 11	93511-32027	C - 8
90109-082G0	C - 7		E - 3	90387-167Y9	D - 4	90501-147A5	C - 7	93210-09017	B - 10	93603-16219	B - 10
90110-06058	B - 10	90201-08410	B - 15	90387-18004	D - 4	90501-16016	C - 7		C - 4	93604-10011	B - 8
90110-08096	C - 14	90201-08512	B - 8	90387-18005	D - 4	90501-224J9	C - 8	93210-11073	E - 7	93608-33002	C - 13
90111-06029	E - 8	90201-086P8	C - 14	90387-18007	C - 4	90506-16500	E - 7	93210-12759	B - 11	93612-16254	B - 3
90116-06541	B - 2	90201-096J9	B - 2	90387-20006	C - 10	90508-142B5	C - 9	93210-14369	C - 5		C - 4
90119-06001	C - 15	90201-10118	E - 6	90387-22001	C - 10	90508-162B2	E - 14	93210-15414	B - 9	9383B-13218	C - 10
90119-06096	D - 2		E - 8	90387-225N2	E - 5	90508-26561	C - 12	93210-16716	C - 5	94108-21012	D - 14
90119-06192	D - 2	90201-10119	E - 7	90401-08038	B - 11	90508-282B8	E - 7	93210-17570	C - 7	94108-21015	D - 14
90119-06225	D - 2	90201-12166	B - 10	90401-10159	B - 11	90508-282B9	E - 7	93210-19123	C - 5	94108-2112Y	D - 14
	D - 8	90201-127E1	E - 9	90401-10172	E - 6	90508-291A8	C - 13	93210-196A4	C - 10	94110-19009	E - 2
90119-08238	D - 3	90201-145M4	C - 14		E - 8	90508-30743	C - 7	93210-21276	E - 11	94110-19011	E - 2
90122-06035	B - 12	90201-14740	D - 5	90430-06014	B - 2	91314-06030	B - 10	93210-32172	C - 5	94110-1913B	E - 2
90149-05162	E - 10	90201-15701	C - 5		B - 7	91316-04012	B - 13	93210-47675	B - 11	94209-21229	D - 14
90149-06011	D - 11	90201-160F6	D - 4		B - 8	91317-05008	D - 4	93300-60804	C - 14	94210-19222	E - 2
90149-06126	C - 4	90201-162H4	C - 7	90430-08119	B - 11	91317-06012	B - 9	93306-00105	B - 8	94210-19224	E - 2
90149-06250	B - 4	90201-167P7	C - 7		C - 14	91317-06014	E - 6	93306-00317	C - 10	94227-21101	D - 14
90149-06324	E - 9	90201-177G4	C - 7	90430-10188	B - 11	91317-06045	C - 4	93306-00320	C - 10	94309-21161	D - 14
90149-06326	C - 4	90201-203U1	E - 3		C - 4	91317-06055	C - 4	93306-07202	E - 2	94316-19156	E - 2
90149-06327	D - 15	90201-20685	C - 7	90445-09095	D - 11	91317-06070	C - 4	93306-20335	B - 4	94321-19135	E - 2
90151-04001	D - 4	90201-247L2	D - 8	90445-09220	D - 11	91317-08020	C - 3	93306-20447	C - 10	94330-21084	D - 14
90152-06010	C - 7	90201-286K9	D - 8	90445-11185	D - 11	91401-20012	E - 7	93306-20648	B - 4	94416-21005	D - 14
90154-05026	E - 11	90202-05193	D - 11	90445-112K0	B - 2	91401-25015	E - 7	93306-27205	E - 2	94418-19003	E - 2
90159-06078	D - 3	90202-08045	B - 13	90450-22017	B - 9	91808-16023	B - 2	93306-27208	C - 10	94591-53114	B - 7
90159-06092	C - 8	90206-06090	C - 3		B - 10	91812-16001	C - 5	93306-90403	D - 14	94681-68001	E - 3
90159-06182	D - 3	90209-06096	B - 12	90450-25037	B - 9	91A20-05065	B - 9	93306-90501	C - 12	94701-00410	B - 2

NUMERICAL INDEX

PART NO.	GRID NO.	PART NO.	GRID NO.	PART NO.	GRID NO.	PART NO.	GRID NO.	PART NO.	GRID NO.	PART NO.	GRID NO.
94701-00411	B - 2	95827-08012	C - 14								
94703-00410	B - 2	97007-05016	E - 14								
94703-00411	B - 2	97027-06012	C - 15								
95027-06010	B - 2	97027-06016	B - 7								
	C - 9	97707-60016	D - 2								
	D - 4	97801-03008	D - 11								
95027-06012	B - 8	98502-04012	B - 13								
	B - 11	98507-05010	E - 8								
	C - 15	98507-05020	E - 5								
	E - 4		E - 14								
95027-06016	D - 11	98507-06025	C - 4								
	E - 4	98706-04012	E - 6								
95027-06020	C - 13	98707-06025	D - 11								
	D - 8	98907-06025	D - 11								
95027-06025	B - 7	98980-06008	C - 3								
	B - 8	99001-08600	B - 10								
	B - 9	99009-12400	B - 10								
	B - 10	99009-16400	C - 7								
	B - 11	99009-17400	C - 7								
	C - 5	99009-22500	C - 5								
95027-06035	B - 3	99009-45500	E - 2								
	C - 5	99530-08012	B - 10								
95027-06050	D - 4	99530-08016	C - 5								
95027-06065	B - 8	99530-10114	B - 10								
	B - 11		C - 4								
95027-08012	C - 15	99530-10116	C - 4								
95027-08020	D - 15	9Y581-92111	E - 3								
95027-08035	D - 8										
95027-08040	C - 14										
	D - 8										
95027-08065	C - 14										
95027-10016	C - 4										
95607-05100	E - 10										
	E - 14										
95607-10200	D - 7										
95617-08620	B - 2										
95701-06500	E - 6										
95704-06500	B - 3										
95707-08500	B - 2										
	C - 14										
	E - 3										
95817-08016	C - 15										
95817-08030	C - 3										
95817-10050	C - 14										
95827-06010	B - 9										
95827-06012	D - 15										
95827-06014	E - 14										
95827-06016	D - 3										